

Installation Manual

100 Series



AHE-125-DN1



Contents

Caution Notes.....	1
Installation Checklist	2
Introduction	4
System Features	7
Component Cut-Aways	9
Installing the Aqua-Hot	11
Installation of the Expansion Bottle.....	12
Mounting the Burner to the Vehicle.....	13
Mounting the High Altitude Bypass.....	14
Combustion Air & Exhaust Systems.....	16
Burner Harness	18
Connecting the Burner to the Aqua-Hot.....	21
Burner Connections	22
Burner Plumbing Requirements.....	23
Wiring the Aqua-Hot	24
House Power Sense	26
Connecting the 125D to 12V DC Power	27
Connecting the Aqua-Hot to AC Power	28
Installing Heat Exchangers.....	29
Heat Exchanger Locations and Clearances.....	30
Mounting the Heat Exchangers.....	31
Wiring the Heat Exchangers	32
Plumbing the Heating Loop.....	33
Domestic Water System Requirements.....	35
Plumbing the Domestic Water System	35
Mounting the Aqua-Hot LCD	36
Operating the LCD.....	37
Configuring the Zones.....	39
Filling the Aqua-Hot.....	40
Purging the Interior Heating Loop	41
Fuel Supply	42
Fuel System	43
Fuel Purge Procedure	46
External Diesel Burner Troubleshooting	47
System Checks.....	49
First Operation.....	50
Winterizing.....	51
Flow Diagram.....	52
Appendix A: System Schematics	53
Appendix B: Measuring Antifreeze	59
Appendix C: Parts & Accessories	60
Warranty	65

Caution Notes

As you read this information, take particular note of the NOTICE, CAUTION, WARNING, and DANGER symbols when they appear. This information is important for safe and efficient use of the Aqua-Hot system.

NOTICE signals a situation where potential damage to the Aqua-Hot could occur.

NOTICE

CAUTION signals a situation where potential harm or risk of minor or moderate injury could occur if you do not follow instructions.



CAUTION

WARNING signals a hazardous situation where potential harm, risk of serious injury, or death could result if instructions are not followed.



WARNING

DANGER signals a situation where immediate risk of serious injury or death will result if instructions are not followed.



DANGER

NOTE: This manual will also use notes sections similar to this one to draw attention to features and practices which must be observed.

Introduction:

The following table is a checklist of important items that need to be completed for a successful install of the **125-DN1** Aqua-Hot heater in your RV. Please confirm each item is properly completed before utilizing the Aqua-Hot heating system.

Should additional assistance be needed, please contact the Technical Support team at 574-AIR-XCEL (574-247-9235), Monday through Friday, between 7:00am and 4:00pm MST. You can also email the service department at servicedept@aquahot.com. Authorized Service Centers can also be found online at www.aquahot.com.

All vehicle installations must comply with the requirements listed in the Recreational Vehicle Industry Association's (RVIA) ANSI/NFPA 1192 Handbook for Recreational Vehicle Standards.

WARNING!

Read and understand all instructions **before** installing the Aqua-Hot unit and the external diesel burner. Aqua-Hot Heating Systems is not liable for damage resulting from failing to follow instructions contained in this, and any other Aqua-Hot documentation relevant to this unit.

Improper installation, adjustments, service and maintenance can cause personal injury or loss of life. Reference the installation and user manuals **before** installation or service.

Contact your authorized service or Aqua-Hot Heating Systems if you have any questions **before** starting installation.

WARNING

If the information in this manual is not followed exactly, a fire or explosion may result, causing property damage, personal injury, or death.

Completed	Description	Page No.
	Aqua-Hot Installed	11
	Expansion Bottle Mounted	12
	Diesel Burner Installed/Mounted	13
	High Altitude Bypass Mounted	14
	High Altitude Bypass Fuel Pump (Horizontal)	44
	Diesel Burner Air System Installed	16
	Diesel Burner Exhaust System Installed	17
	Diesel Burner Harness connected to Burner	18-20
	Diesel Burner Harness connected to solenoid	20
	Diesel Burner Harness connected to fuel pump	20
	Diesel Burner Harness connected to Aqua-Hot	20
	Aqua-Hot "to Heat Source" port connected to Burner "In" Port	21-23
	Aqua-Hot "from Heat Source" port connected to Burner "Out" Port	21-23
	RV Thermostats OR Thermistors wired to Aqua-Hot	24-25
	House Power Sense wire connected	26

Completed	Description	Page No.
	12VDC connected to Aqua-Hot	27
	120VAC connected to Aqua-Hot	28
	Cozy's installed	29-31
	Cozy's wired	32
	Cozy's plumbed (in the bottom port, out through the top port)	33
	Domestic Water System plumbed to the Aqua-Hot	35
	Domestic Water Flow through the Aqua-Hot regulated to 0.8 GPM	35
	Aqua-Hot LCD mounted in correct orientation	36
	Heating Zones configured on LCD	39
	Aqua-Hot filled with proper mixture of ethylene glycol/distilled water heating solution	40
	Aqua-Hot filled and purged properly	41
	Fuel stand pipe installed in vehicle fuel tank	42
	Fuel lines properly installed	43-45
	Fuel system components connected to fuel line in order	43-45
	Fuel line hose clamps fully tightened	43-45
	Fuel system properly purged before operating the burner	46
	System checks performed before first operation	49
	First operation properly performed	50

Read and understand all instructions **before** installing the Aqua-Hot unit and the external diesel burner. Aqua-Hot Heating Systems is not liable for damage resulting from failing to follow instructions contained in this, and any other Aqua-Hot documentation relevant to this unit.

- Read this manual **before** installing or using the Aqua-Hot System to reduce the risk of injury to persons or damage to the equipment.
- The product identity label contains specifications of the unit, to what standards it has been tested, and important safety notices.
- Disconnect electric wiring to the Aqua-Hot System before welding or plasma cutting the RV to avoid damage to equipment.
- The Aqua-Hot tank and heating loop operate at 0.0 PSI (zero pressure system). Air pressure to the tank must not exceed 18 PSI. Exceeding this rating will cause internal damage to the Aqua-Hot.
- Use caution when working on or near any propane/diesel fuel system.



- DO NOT connect the 12-volt DC power to the Aqua-Hot if the vehicle requires welding.
- At maximum operating temperature, the coolant will be very hot and scalding. Hot vapor or coolant may cause in serious burns or injury. Be aware of hot surfaces.
- Use special caution when children are present. Children must not be allowed to play with the heater or perform cleaning and maintenance.
- Installation and repairs may only be carried out by an authorized, factory-trained Aqua-Hot technician. The heating system must be installed in accordance with local codes, or in accordance with the Standard for Recreational Vehicles, (RVIA) ANSI A 119.2/NFPA 501C, NFPA 1192.
- At maximum operating temperature, the hot air outlet will be very hot that may result in serious burns or injury. Be aware of hot surfaces.
- The diesel burner must be installed in a location that is closed off from living quarters and accessible only from the exterior of the vehicle.
- The burner produces very hot temperatures that can ignite surrounding flammable materials. The burner should be turned off when loading or unloading flammable materials.

Safety Features

Low-Voltage Shutdown

The Aqua-Hot Controller is designed to operate between 11V DC and 16V DC. If the Controller detects that it is receiving voltage below 11.8V DC, a System Voltage fault will trigger a display on the LCD screen. If the Controller system drops below 11.2V DC for 30 seconds, it will discontinue operation of the Aqua-Hot heating system.

Over-Current

An Over-Current fault condition occurs when too much current is drawn by a component, usually a fan or pump. When this fault is triggered, the output channel is shut off until the system has been reset or power-cycled.

Over-Temperature

An over-temperature fault will occur if your Aqua-Hot heating system has reached 218°F. The Controller will deactivate the heater and display an over-temperature fault on the LCD display screen.

Low-Level Cutoff

If the system senses low fluid levels, the heating system will shut down all fans, heat sources, and pumps until the unit is adequately refilled.

House Power Sense

The Aqua-Hot Controller contains within it a fail-safe functionality known as House Power Sense. This functionality serves as a live signal to the Aqua-Hot allowing it to continue operating. If power is lost to the on-board RVC network or other on-board control systems, the controller is signaled to shut down operation until a 12V DC power signal is returned to the unit.



NOTE: Contact your Authorized Service Center or Aqua-Hot Heating Systems if you have any questions **before** starting installation. Information can be found online at www.aquahot.com.

Safe Installation of the Diesel Burner

Be sure to become familiar with the installation process and the documentation before installing in the vehicle.

- Make sure to protect the burner during installation. Do not drop or stand on the burner.
- Avoid abruptly shutting down the burner prior to the purge cycle. The burner fan will continue to run for several minutes after being shut off to cool down and purge unused fuel.
- Only turn off the burner at the switch in the interior of the vehicle.
- Do not disconnect the 12V DC power supply prior to the purge cycle.
- Only shut down the burner via the battery disconnect in the case of an emergency or danger.
- Do not allow the wiring or wiring harness to come into contact with sharp edges on metal panels. The wires can become damaged and short circuit and potentially cause a fire. Use caution when installing the wiring.
- Protect any vehicle parts near the burner from excessive heat damage, or from contamination from fuel.
- Make sure the internal combustion burner will not pose a fire hazard even in an overheat situation. Take care in placing the burner with enough space from vehicle parts and that the burner will have ample ventilation.
- The serial label must be visible and legible after the burner has been installed.
- All precautions must be taken to minimize the risk of personal injury or damage to the burner or vehicle.
- It must be obvious to the user when the burner is switched on or off.
- The burner may not be mounted in a position above the 125DN expansion tank.

Fuel Supply

- Do not use the heater in enclosed spaces such as a garage. The fumes produced from the exhaust can be toxic. Do not use the burner while refueling or while other appliances are being serviced or refueled.
- The fuel filler neck should be installed in a compartment that is closed off from living quarters and must have a tightly fitting cap to prevent any fuel leaks.
- A visible, legible sign must be attached to the filler neck that the burner be turned off before refueling. A similar warning is included in the manufacturer's operating manual.

Exhaust System



- Do not operate the burner in an enclosed space or a space that does not have exhaust ventilation. Fumes from the exhaust may be toxic.
- The exhaust system must be positioned so that the fumes will not get into the interior of the vehicle through ventilation openings or windows.

Combustion Air Inlet

- The burner combustion chamber air must not be taken from the interior of the vehicle, only fresh air from the exterior.
- An intake line is required for the combustion air.
- The air inlet must be positioned in an unobstructed manner.

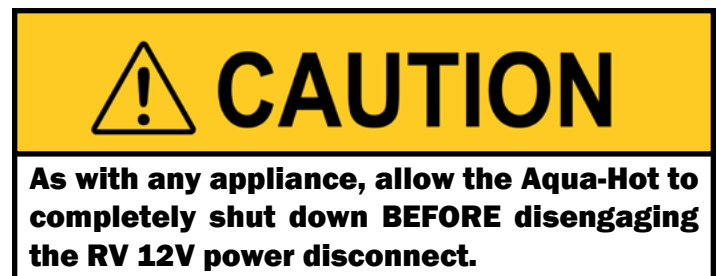

System Overview

The Aqua-Hot 125D is a Hydronic Heating System that can provide heat and hot water on demand using a built-in electric heating element and an external diesel burner.

The Aqua-Hot Heating is a 2-in-1 System

1. Interior heating system: provides quiet, comfortable interior heat and even temperatures.
2. Tank-less hot water system: provides a flow of comfortable hot water.

The Aqua-Hot heating system heats an ethylene glycol-based antifreeze and distilled water solution that is stored in the Aqua-Hot's boiler tank. This fluid solution must be up to operating temperature before the Aqua-Hot will provide interior heat or hot water. The tank-less hot water system produces approximately 0.8 GPM of hot water. This system is also hot water priority, so it will shut off the heat any time hot water is called for. Read more about it to the right.

To get the Aqua-Hot to temperature, turn the electric heating element and/or the external diesel burner to the "ON" position on the Aqua-Hot LCD screen (shown below), or on the RV control panel. It may take up to 20 minutes to get to operating temperature before heat or hot water are available.

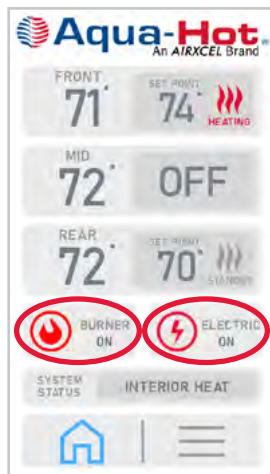

For continuous hot water or heat in colder conditions, it is recommended to utilize the external diesel burner. The electric heating element will provide heat only in mild conditions and provide light duty hot water needs.

Should additional assistance be needed, please contact the Technical Support at 574-AIR-XCEL (574-247-9235), Monday through Friday, between 7:00am and 4:00pm MST.

Important Notes:

- A qualified installer or service technician must perform equipment installation or service. Contact Aqua-Hot for Factory Authorized Service Centers or Certified Technicians located near you at www.aquahot.com/service-help, or call us at 574-AIR-XCEL (574-247-9235).
- Warranty work must be performed by an Aqua-Hot Authorized Service Center.
- Your on-product identity label contains the specifications of your unit. Factory settings may be adjusted by the vehicle manufacturer, confirm final setting with your dealer.
- This heating system has been certified for installation only in recreational vehicles, not certified for use in boats.
- The Aqua-Hot heating system operates independently of the vehicle engine and is connected directly to the electrical system of the vehicle. The diesel burner is only connected directly to the fuel system of the vehicle.
- Please read this manual and follow instructions to avoid injuries during installation and/or operation.

Hot Water Priority System

The Aqua-Hot 125D is a Hot Water Priority heating system. Meaning that the 125D cannot heat the interior of the RV and produce hot water simultaneously. When hot water is being used, the interior heating system will shut off temporarily, until hot water is no longer being used.

Heat Priority Option:

The Aqua-Hot comes equipped with the three-way valve (sometimes known as the summer/winter valve). This controls the flow of the antifreeze and water heating solution within the Aqua-Hot to deliver either hot water or interior as priority. Tapping on this element will change the valve's orientation. When this element displays "INT. HEAT", this valve is oriented to provide interior heat by circulating the heating solution throughout the interior heating zone. When the element says "HOT WATER", the valve is oriented so that the heating solution is routed to prioritize hot water.





Exhaust system MUST NOT terminate beneath the vehicle and not less than 3 feet from an openable window.

Combustion Air MUST BE supplied from outside the vehicle.

Suitable for water (potable) heating and space heating.

THIS APPLIANCE OPERATES ON BOTH DC AND AC POWER.

USE COPPER CONDUCTORS ONLY!

Use a circuit breaker that cuts power at 20-Amps maximum for over-current protection for the 120-VAC power supply.

Mount the Heater and Unit so that the Access cover can be easily removed for service.

For Detailed Information, reference the Owner's Manual or contact Aqua-Hot Heating Systems Inc. at 574-AIR-XCEL (574-247-9235).

Minimum Service Clearances
 Front - Open Access
 Back - 1 Inches
 Top - 8 Inches
 Sides - 1 Inches

This appliance must be installed in accordance with local codes or, in the absence of local codes, the Standard for Recreational Vehicles, ANSI A119.2/NFPA 1192 or CAN/CSA-Z240 RV.



Meets or Exceeds: UL 307B, UL 174
 CSA/CAN B140.0-03
 CAN/CSA-C22.2 No. 110-94

Listing 20L01

Max Tank Pressure	0 PSI
Watts (DC)	84W
Watts (AC)	1500W
Tank Capacity	1.8 gal (Ethylene Glycol)
Volts/Amps	12VDC, 7A
Volts/Amps/Frequency	120VAC, 13.75A, 50/60Hz
Burner Model	Webasto TT Evo
Burner Fuel	Diesel
Burner Rating	17,060 BTU/hr

Model Number: AHE-125-DN1

Serial Number: A125DN-210000

Burner Serial Number: XXXXXX

7501 Miller Drive • Frederick, CO 80504 • 574-AIR-XCEL • www.aquahot.com

NOTE: This product label is attached to the side of the Aqua-Hot, and provides a ready reference to specifications, test standards, and important safety notices.



Figure 1

System Specifications

Electric Element

Power Consumption1500 W (maximum)
 Voltage120V AC

DC Power

Consumption 84 W (maximum)

Zone Heat Circulation

Pumps1
 Power Consumption (max)..... 21W
 Voltage 12V DC

Heating Zones

Maximum3

Domestic Water Heating

Maximum 0.8 GPM

Physical Specifications

Dimensions.....17.66”L x 7.50”W x 11.50”H
 Dry Weight45lbs.
 Wet Weight.....59lbs.

All vehicle installations must comply with the requirements listed in the Recreational Vehicle Industry Association's (RVIA) ANSI/NFPA 1192 Handbook for Recreational Vehicle Standards.



Figure 2

System Specifications

Diesel Burner

Heat Flow	8,500 to 17,000 BTU
Diesel Fuel Consumption.....	0.08 to 0.13 gal/hr
Operating Pressure (med heat).....	36.25 PSI
Flow Rate (minimum).....	66 gal/hr

DC Power

Consumption	12-21W
Operating Voltage Range.....	9.6 to 15V

Operating Temperatures

Burner Operation	-40 to 176 °F
Burner Storage.....	-40 to 248 °F
Fuel Pump Operation	-40 to 86 °F
Fuel Pump Storage.....	-40 to 194 °F

Physical Specifications

Dimensions.....	8.6”L x 3.6”W x 5.8”H
Weight.....	4.8 lbs

5000053A		Webasto	
ASSEMBLED IN USA			
Heater Model	DRW2010.46		
Voltage/Power	12V/20W		
Output	17000 BTU/hr		
Fuel Type	Diesel No. 1/No.2 and Arctic		
Max. Operating Pressure	36.25 PSI		
			
Heater No. 447900A Vers.46		Serial No.000001	
Year of Installation	2021	2022	2023 2024 2025

NOTE: This product label (shown above) is attached to the side of the burner and provides a ready reference to specifications, test standards, and important safety notices.

All vehicle installations must comply with the requirements listed in the Recreational Vehicle Industry Association’s (RVIA) ANSI/NFPA 1192 Handbook for Recreational Vehicle Standards.

- | Aqua-Hot 125DN | |
|----------------|--|
| 1. | Fluid Circulation Pump |
| 2. | Tempering Valve |
| 3. | Aqua-Hot Controller |
| 4. | Antifreeze and Water Heating Solution Tank |
| 5. | AC Electric Element |
| 6. | AC Activation Relay |
| 7. | Plate-to-plate Heat Exchanger |
| 8. | Three-Way Valve |
| 9. | Zone Air-Bleed Valve |
| 10. | Fluid Expansion Port (to overflow bottle) |
| 11. | Zone Return |
| 12. | Fluid Fill Port |
| 13. | Zone Supply |
| 14. | Service Panel |
| 15. | External Diesel Burner Supply |
| 16. | External Diesel Burner Return |
| 17. | Domestic Cold-Water Inlet |
| 18. | Domestic Hot-Water Outlet |
| 19. | Domestic Low Point Drain |
| 20. | Cabinet Drain |

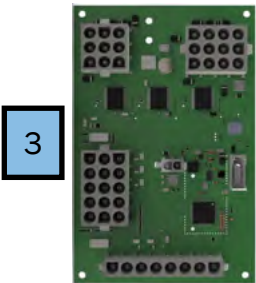

Figure 4

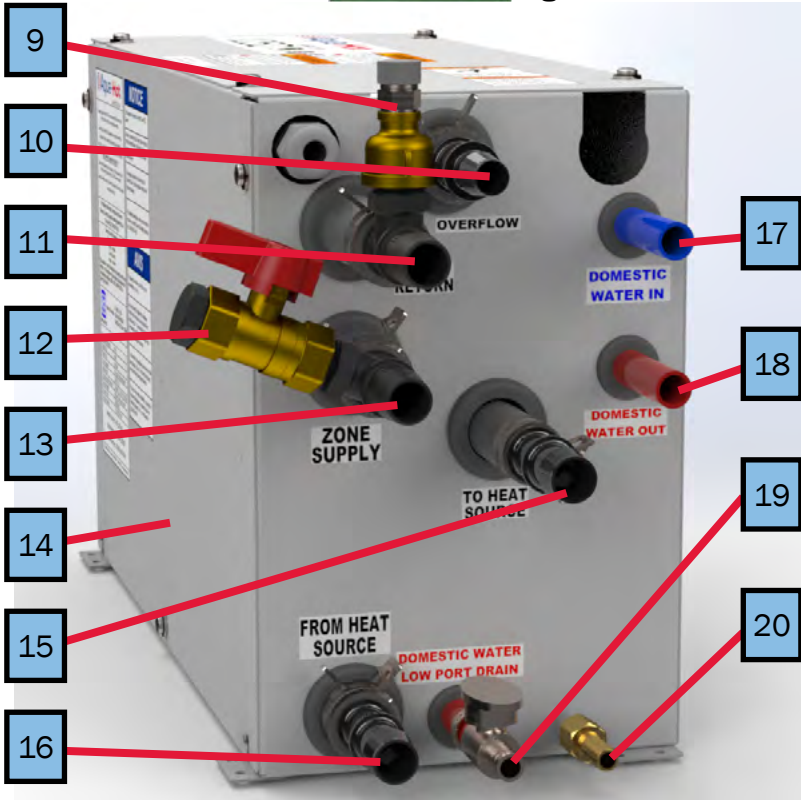

Figure 5

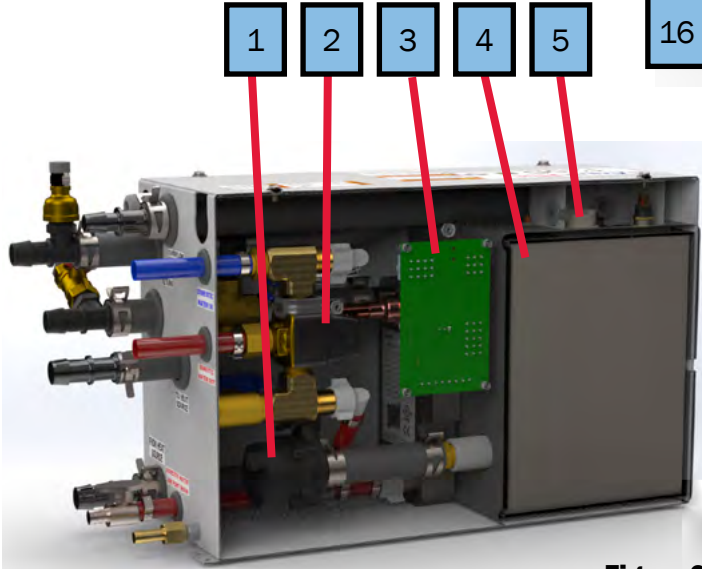

Figure 3

NOTE: The side panel in the view above has been made transparent to aid in the explanation of the heater. DO NOT remove the side panel. Doing so risks irreparable damage to the Aqua-Hot. Only remove the service panel for service.

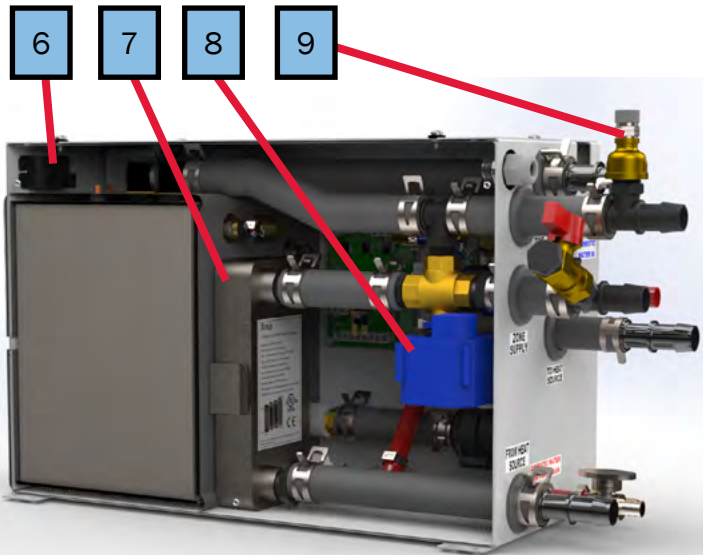

Figure 6

Aqua-Hot Diesel Burner	
1.	Combustion Air Fan
2.	Fluid Outlet
3.	Fluid Inlet
4.	Combustion Chamber
5.	Circulation Pump
6.	Exhaust Gas Temperature Sensor
7.	Exhaust Outlet
8.	Control Unit
9.	Burner Motor
10.	Fuel Inlet
11.	Combustion Air Inlet
12.	Fuel Pump
13.	High Altitude Bypass Assembly

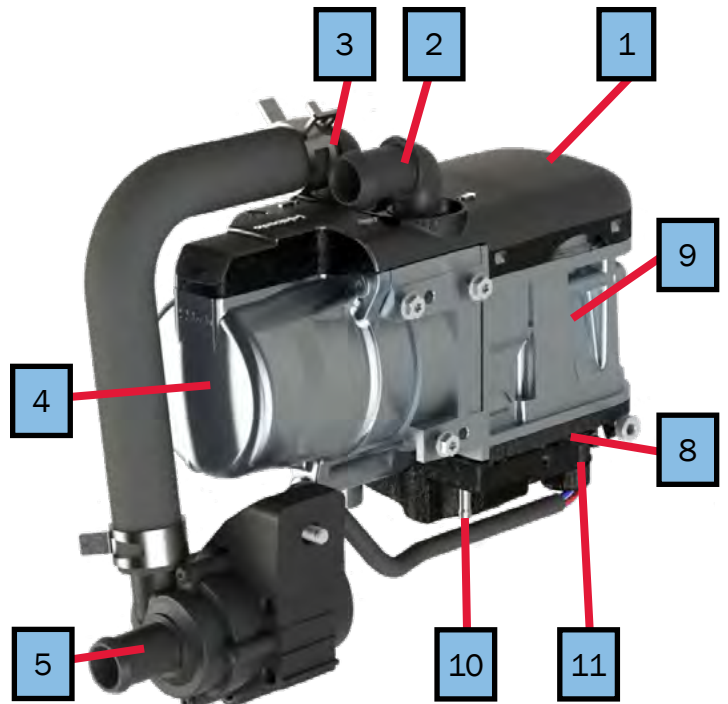

Figure 7

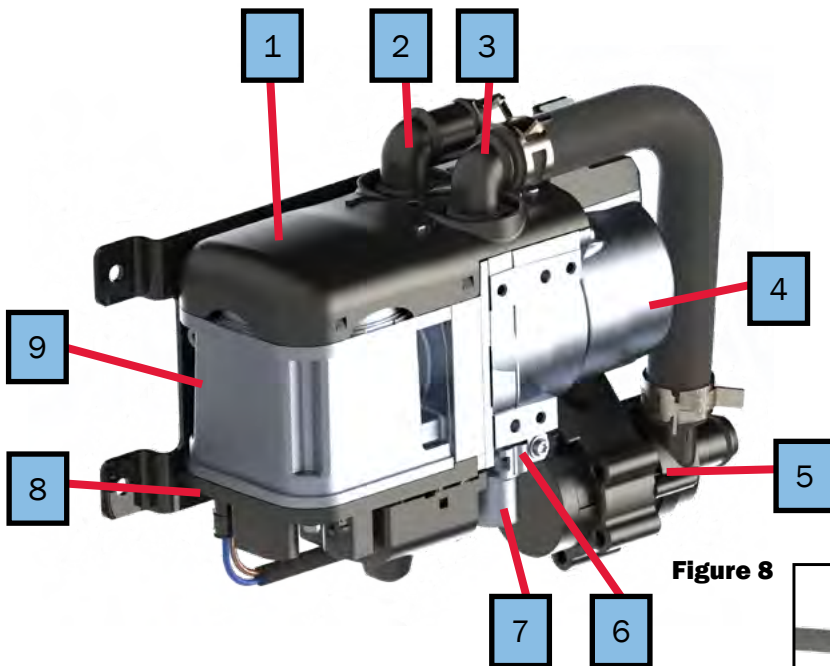

Figure 8



Figure 9

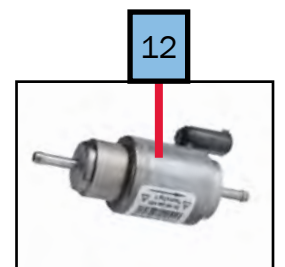
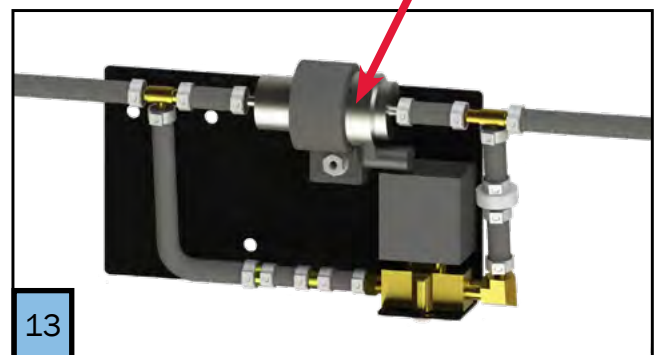

Figure 10



Installing the Aqua-Hot

Install the Aqua-Hot in a compartment which protects the unit and allows service access to the top and front panel of the Aqua-Hot.

1. Reference the following illustrations below for mounting information.
2. Secure the Aqua-Hot to the RV floor using appropriate mounting hardware to suit flooring material and tolerances.
3. The Aqua-Hot is best placed where easy access to the top and front is guaranteed for service.

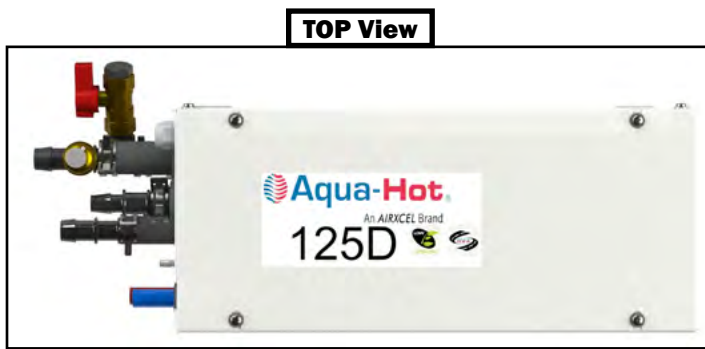

Figure 12

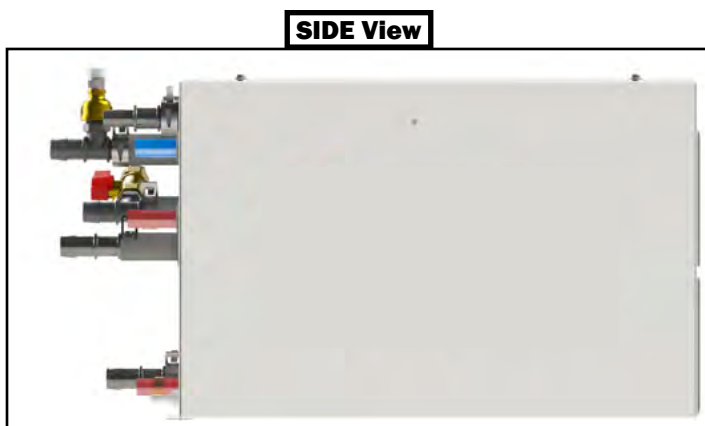

Figure 13

Support and Clearances

Make the following considerations when supporting the Aqua-Hot to ensure its most optimal operation and location. Dimensions for the mounting tabs are shown below.

- Ensure that the floor of the mounting location can support at least 70lbs.
- Use a #10 screw (5mm) to secure the Aqua-Hot in place on the RV floor. Use at least 1 screw per mounting tab (3 tabs).
- The best place for the Aqua-Hot heating system is in a cabinet or storage space, making sure there is ample space to remove the service panels on the top and side.

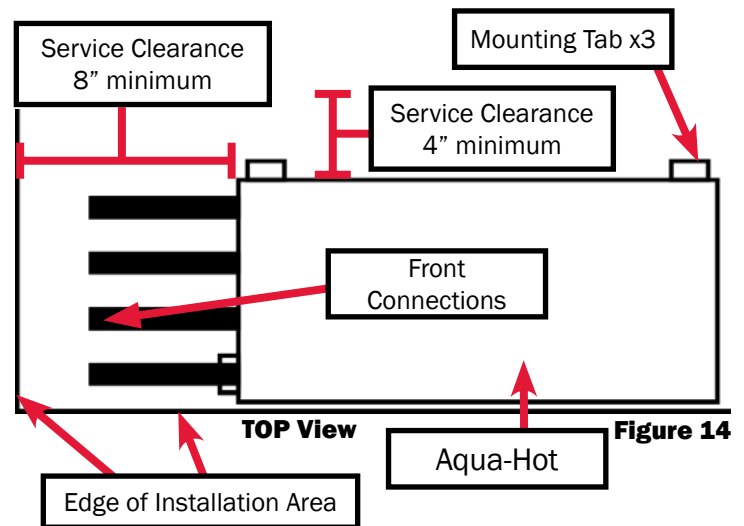

Figure 14

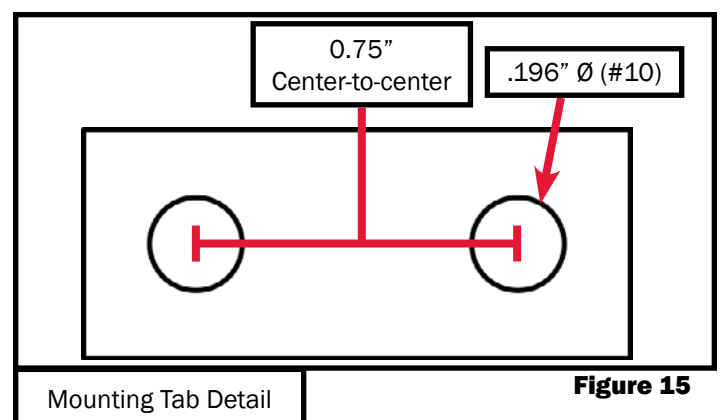

Figure 15

Installation of the Expansion Bottle

Introduction:

The fluid expansion bottle is integral to the operation of the Aqua-Hot. It provides an area for hot, expanded fluid to empty into, and also protects the Aqua-Hot from low-fluid, which could lead to catastrophic damage of the Aqua-Hot.

NOTE: Before securing the expansion bottle to the side of the Aqua-Hot or its mounting location, the boiler tank must be filled with the heating solution. The expansion bottle must be higher than the unit for this to happen to avoid air locks. See "Filling the Aqua-Hot" on page 38 for more information.

Follow the directions in this section to correctly install the fluid expansion bottle.

Installation Procedure:

1. Place the expansion bottle in position on the side of the Aqua-Hot or other mounting location in the RV.
2. Secure the expansion bottle using either self-tapping screws driven into the dimples in the area of the Aqua-Hot shown in Figure 18, or mounting hardware specific to the mounting location in the RV. Please only use the length of hose provided, or less, if the bottle is not mounted to the side of the Aqua-Hot. Additionally, there should be a gradual rise from the Aqua-Hot to the expansion bottle if it is not mounted to the Aqua-Hot.
3. Drill a hole in the floor of the RV to allow the overflow tube to vent to the exterior of the vehicle (Figure 19).
4. Cut the hoses to length if necessary.
5. Place a hose which runs from the lower fitting of the expansion bottle to the expansion bottle connection shown in Figure 17. Secure this hose in place with 2 constant tension hose clamps.
6. Place the overflow hose so that it connects to the upper fitting of the expansion bottle, and exits through the hole drilled through the RV floor in step 3 (Figure 19). Secure this hose to the upper fitting with a constant tension hose clamp.
7. Locate the wires of the expansion bottle and connect them to wires J43 and J44 on the wiring harness.

NOTE: Avoid any bends or dips in the overflow tubing from the Aqua-Hot. Air can become trapped in these bends and will prevent excess antifreeze and water heating solution from depositing properly in the expansion bottle.



Figure 18

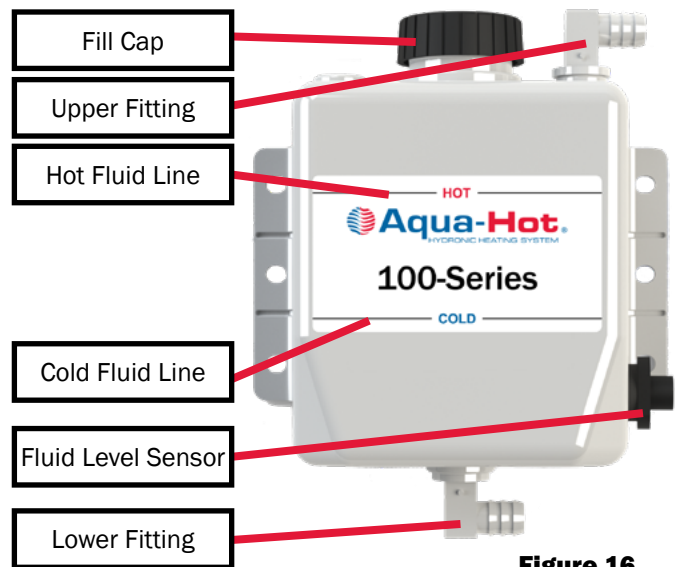

Figure 16

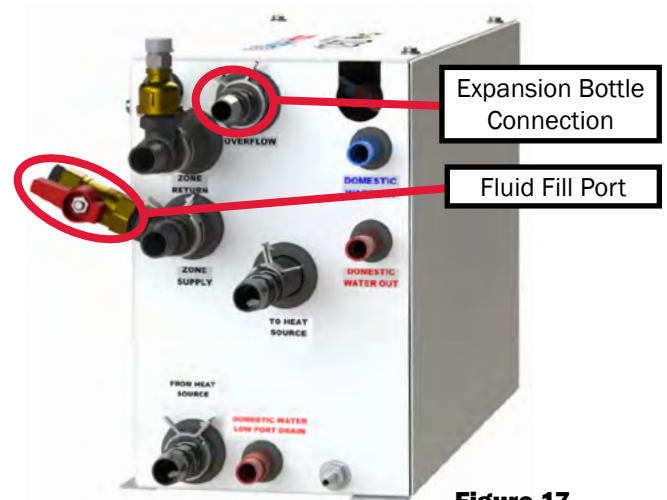

Figure 17

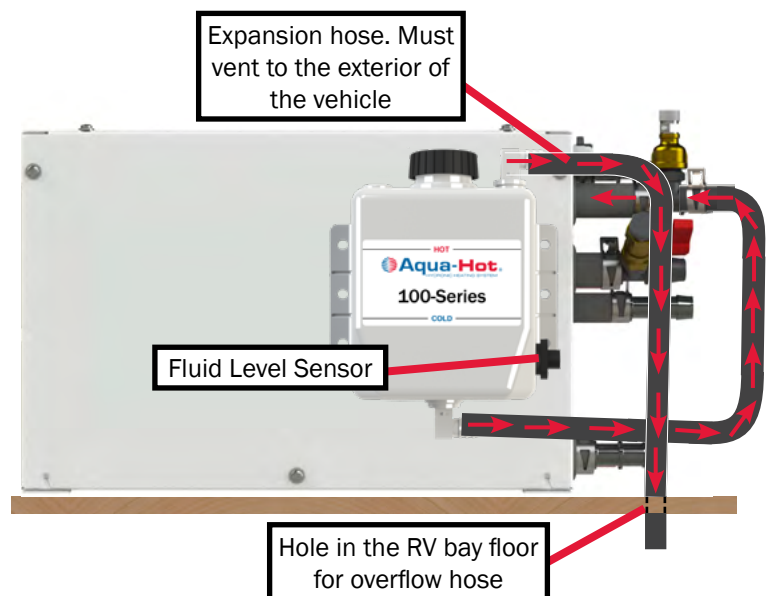

Figure 19

Mounting the Burner to the Vehicle

Install the external diesel burner in a location separate from the living spaces that protects the unit and allows service access to the burner.

- Reference the following illustrations below for mounting information.
- Secure the burner to the bracket using appropriate mounting hardware, at least (3) M5 bolts torqued to 6 lb-ft.
- The bracket must be secured to the vehicle with at least 4 M6 screws.
- The burner is best placed in a location where it can be easily accessed for service and maintenance.
- The burner must not be mounted higher than the expansion bottle.

- The burner must be fastened on the bracket with at least 3 M5 bolts (see Figure 23).
- The burner fastening screws are approved for bracket metal thickness of 0.06in - 0.12in.
- The images below are examples of the burner bracket with dimensions.



CAUTION

Before drilling holes in the vehicle, consult the manufacturer for recommendations and limitations. Do NOT weld to the vehicle frame.



Figure 20

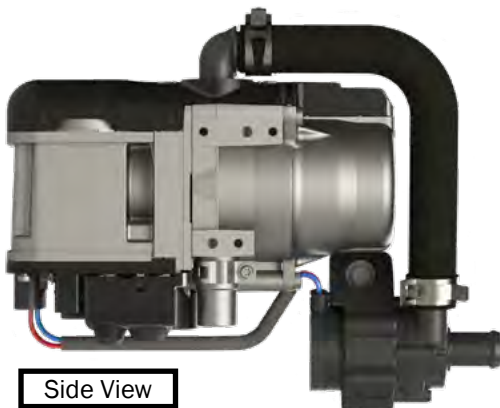

Figure 21

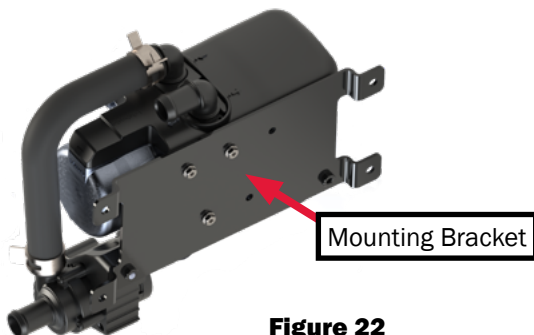

Figure 22

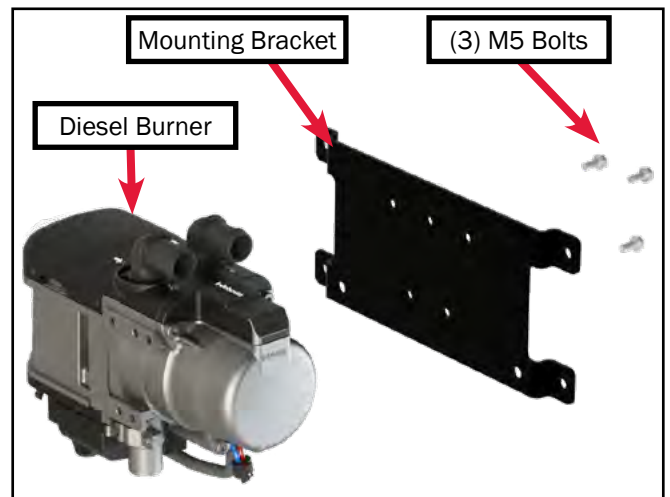

Figure 23

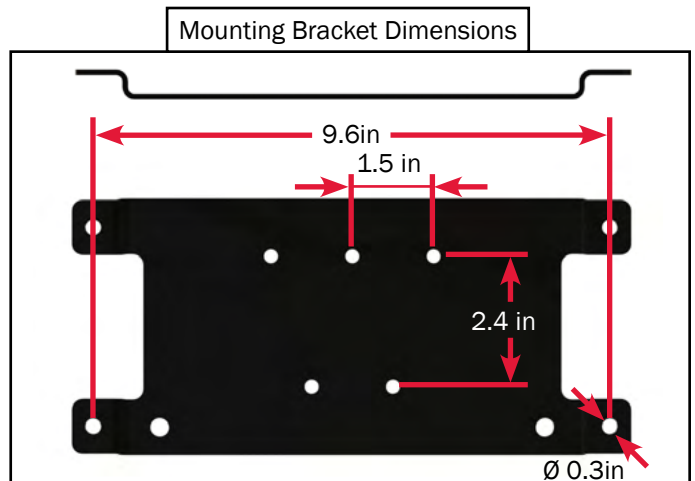

Figure 24

Mounting the High Altitude Bypass

The High Altitude Bypass is to modify the diesel fuel amount when the RV is at an elevation of over 5,000 ft.

- Reference the following illustrations below for mounting the High Altitude Assembly to the burner.
- Fuel pump is required to be installed horizontally.
- It is recommended to use a minimum of three mounting holes.
- Do NOT mount the fuel pump higher than the fuel inlet on the burner (see Figure 7 on Page 8 and the Fuel System section pages 40-44 for reference).

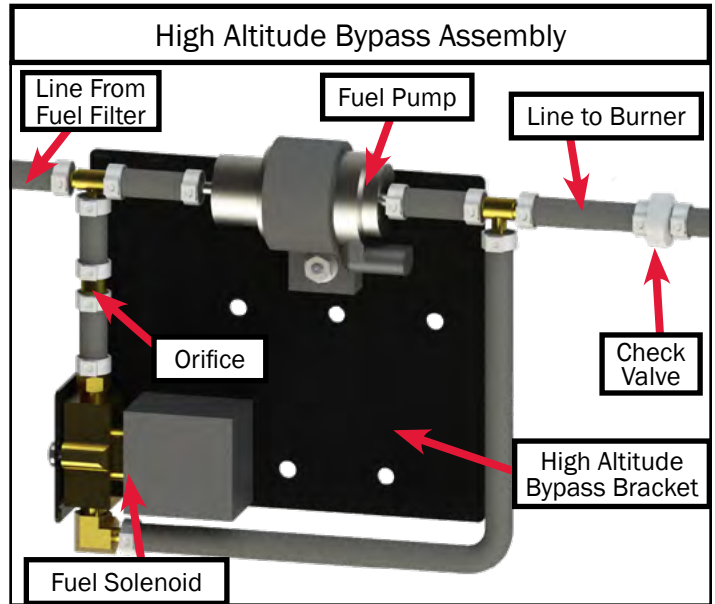

Figure 25

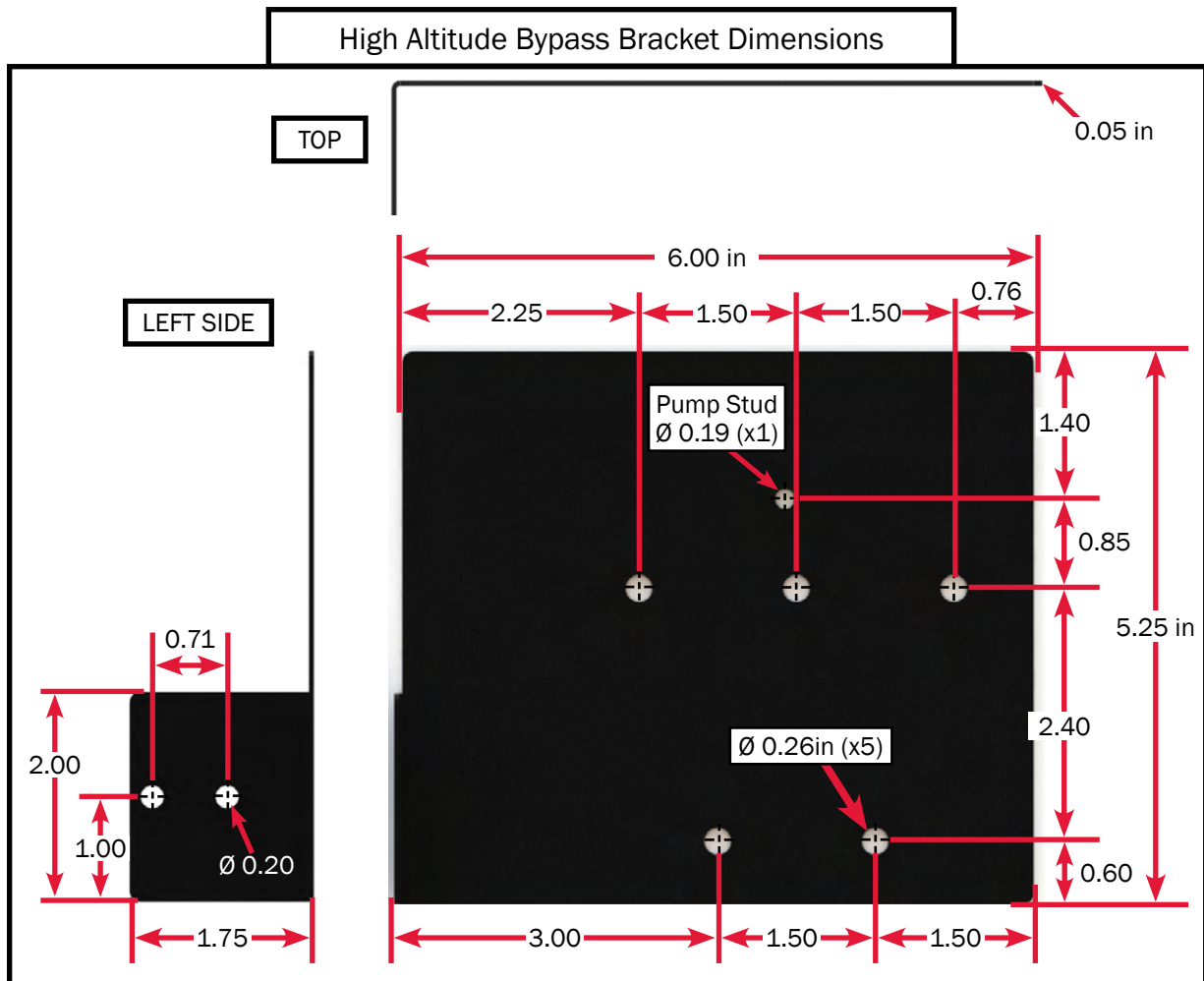

Figure 26

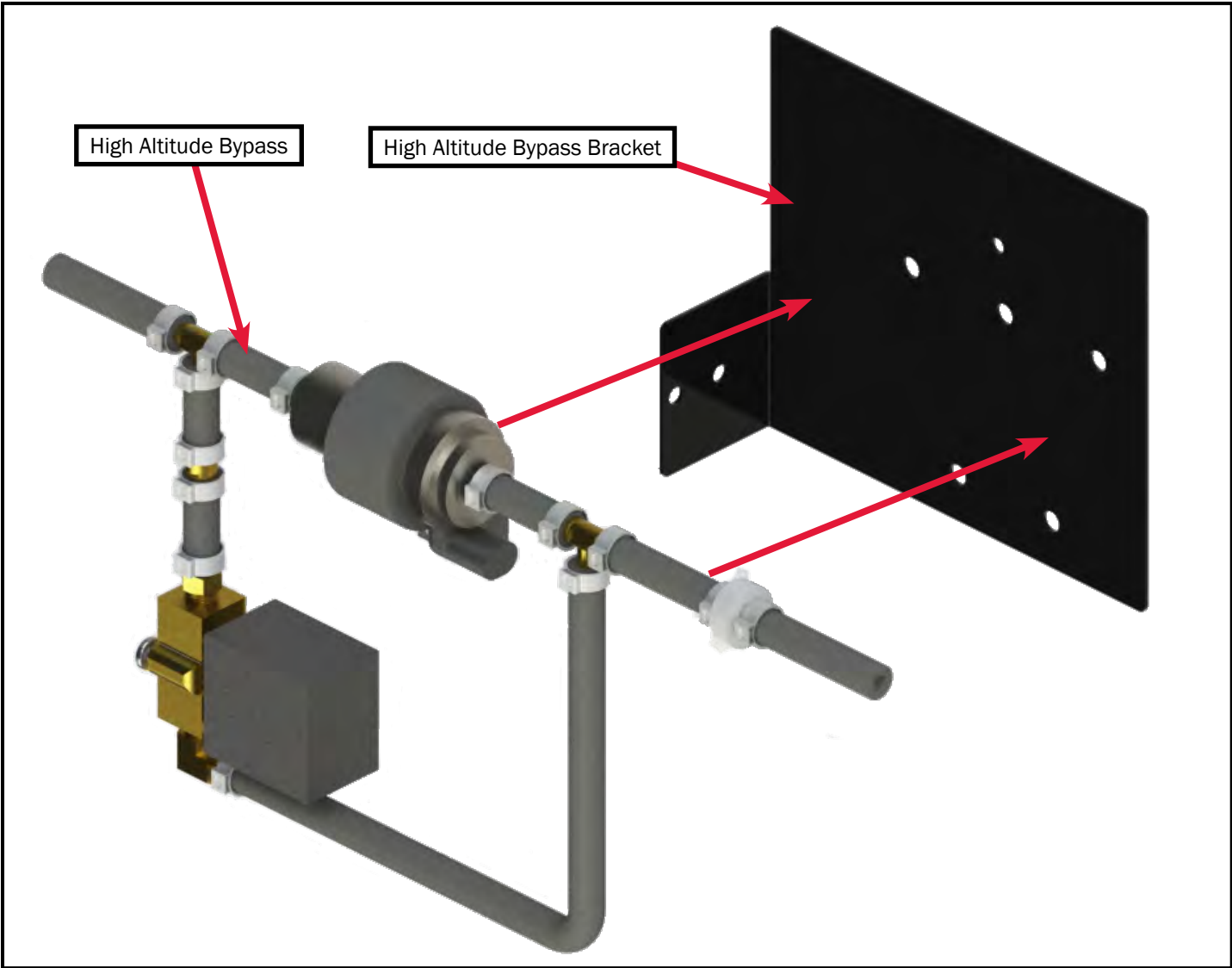

Figure 27

Combustion Air System

The combustion air should not be supplied from living areas. The air intake opening must not point in the direction of travel. It also should be free from potential clogs from snow, debris, or water.

NOTE: The air intake tube cannot be installed downward. A water drain hole (Ø 5/32in) is to be made at the lowest point. The tube should be installed in a position that stays as cool as possible and protected from splashing water.

- There is no air pressure difference between the exhaust gas outlet or combustion air inlet.
- The combustion air intake must be positioned in a way that the intake will not terminate within the vehicle interior or near the burner's exhaust pipe.
- The air intake tube must be located in a cool place.
- The combustion air intake must be positioned high enough so splashing water cannot come into contact.
- It must be positioned as to not become clogged with dirt or debris.
- It should not be able to draw in exhaust fumes.
- It must be positioned away from the face of travel.

The combustion air intake may be installed in the same compartment as the vehicle's fuel tank, but the air intake must come from the exterior. The exhaust must be routed to the exterior and any holes must be splash-proof.

An optional combustion air silencer may be installed as well. The combustion air intake pipe, with a max length of 3ft, can be screwed onto the combustion air connection piece on the burner. The silencer is then screwed as far as possible into the combustion air intake pipe.

Refer to the "Internal Combustion Engine Exhaust and Vehicle Wall Openings" in RVIA's ANSI/NFPA 1192 Handbook for Recreational Vehicle Standards, as well as the National Fire Protection Association's (NFPA) 1192 Standard on Recreational Vehicles for relevant information.

Should this particular application require modification, please contact Aqua-Hot Heating Systems at 574-AIR-XCEL (574-274-9235) for further assistance.

Combustion Air Intake Hose



Figure 28

Burner Bottom View

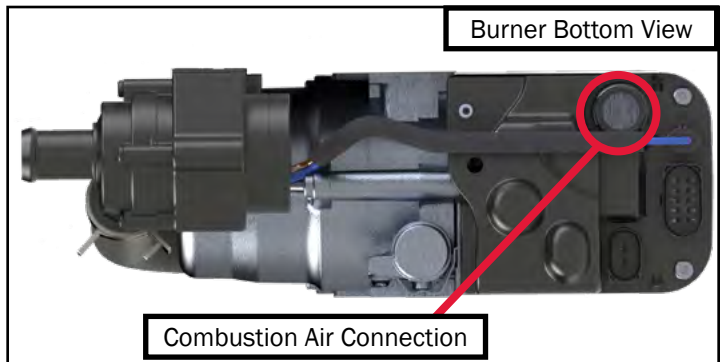

Figure 29

Combustion Air Connection

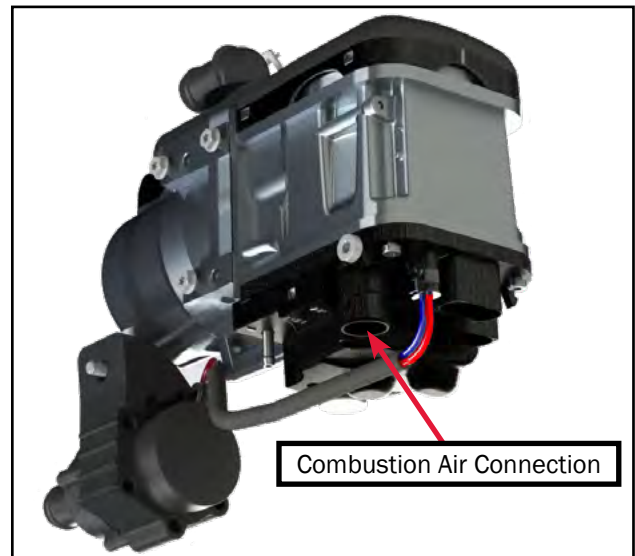

Figure 30

Exhaust System



WARNING

The direction of the exhaust outlet must be directed away from any heat sensitive or highly flammable parts. Failure to do so will result in a fire. Exhaust cannot be routed through the interior of the vehicle, only the exterior. Failure to do so can cause exhaust gas to leak inside the vehicle causing illness and/or death.

The specifications and requirements must be followed carefully. Failure to follow instructions may result in improper and unsafe operation of the 125DN and burner. Please comply with all applicable legal requirements.

- Do not direct exhaust downward, as fire may result when the vehicle is near dry, grassy areas.
- Exhaust must not terminate beneath the vehicle or beneath a window or vent.
- Ensure that the exhaust pipe is routed away from any awnings or slide-out areas.
- Position the exhaust pipe away and towards the rear of the vehicle so the fumes naturally move away while the vehicle is in motion and cannot permeate the interior of the RV.

Instructions

The exhaust pipe, with an inside diameter of 0.86in, can be routed with several bends, total not to exceed 270°, and a minimum bending radius of 2in. The total length must be between 1'6" and 3'.

An optional muffler may be installed near the burner. It may not be fastened to temperature-sensitive vehicle parts. There should be at least 0.8in between the muffler, or exhaust, and temperature-sensitive parts. Thermal insulation may be used on the exhaust pipe.

It is recommended to route the exhaust pipe in a downhill slope. If it is not possible, drill drain holes (0.16in) at the lowest points.

The exhaust pipe opening should be positioned at an angle of 90° (±10°) to the road. A fastener can be mounted at a distance of less than 6in from the end of the exhaust pipe to ensure the opening is at least 90°.

The exhaust pipe must be extended by an additional 0.4in if the vehicle has an under-body shield.

Rigid, stainless steel with a minimum wall thickness of 0.04in or flexible piping of the same material may only be used as the exhaust pipe. The exhaust pipe is secured to the muffler using supplied exhaust clamps.

Exhaust Outlet Requirements

- The exhaust gas must be able to flow freely.
- The exhaust outlet must not be clogged with snow or debris.
- Exhaust outlet must not face in the direction of travel.
- Exhaust fumes may not enter the interior of the vehicle via windows, doors, or other openings.
- The exhaust gas cannot be drawn in for the combustion air.
- The exhaust opening may not be close to the ground.
- If the vehicle has an under-body, the exhaust opening must extend at least $\frac{3}{8}$ in past the vehicle.
- The exhaust line must be secured at least 6in from the exhaust outlet opening, so that the exhaust fumes exits at an angle of 90° (±10°) to the ground.

Exhaust Pipe - Stainless Steel

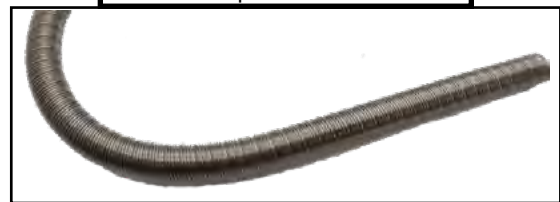

Figure 31

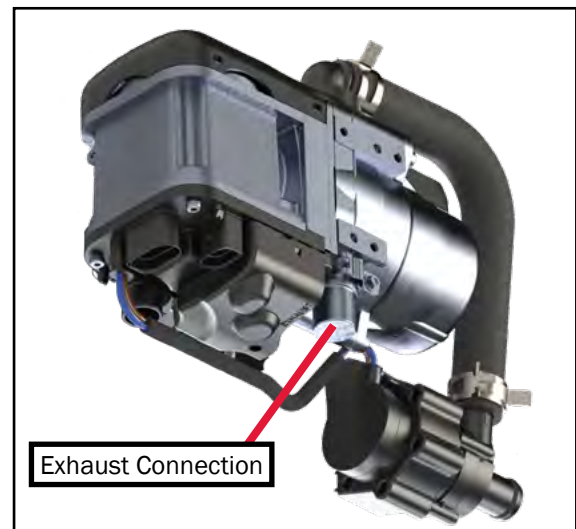

Figure 32

Diesel Burner Wire Harness

The diesel burner and connectors will need to be properly installed. Please note that the connectors will not fit in the incorrect positions.

The connectors and information are shown below.



Figure 33

X3 Plug:

The X3 plug is the connector to the diesel burner.

Manufacturer	Part No.	Common Name
TE Connectivity	1-967616-1	Socket Housing
TE Connectivity	5-965-906-1	Terminal
TE Connectivity	0-0967067-1	Wire Seal
TE Connectivity	967056-1	Plug, Blue (Pins 1, 2, & 5)

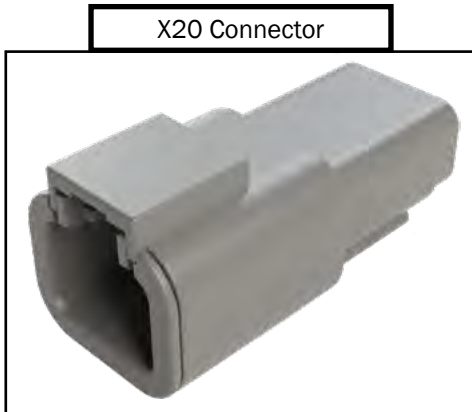

Figure 34

X20 Plug:

The X20 plug is the connector to the fuel solenoid.

Manufacturer	Part No.	Common Name
Deutsche	DPT04-2P	Socket Housing
Deutsche	0460-202-16141	Terminal
TE Connectivity	W2-P	Wedge Lock



Figure 35

X6 Plug:

The X6 plug is the connector to the diesel burner.

Manufacturer	Part No.	Common Name
Amphenol	FCI F671800	Socket Housing
Amphenol	FCI 60013041	Terminal
TE Connectivity	828905-1	Wire Seal

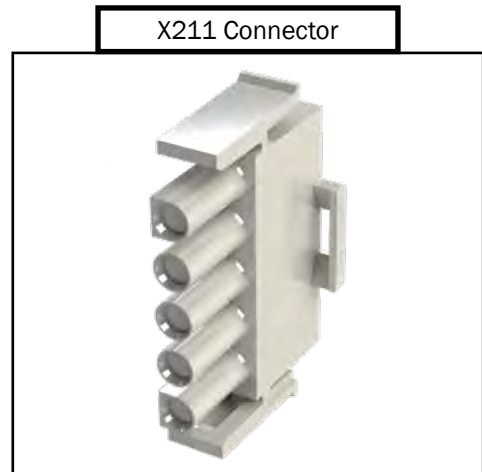

Figure 36

X211 Plug:

The X211 plug is the connector for the burner to the Aqua-Hot.

Manufacturer	Part No.	Common Name
TE Connectivity	350809-1	5-Pin Mate-N-Lok Receptacle Connector
TE Connectivity	350536	Pin
TE Connectivity	350536-1	Socket

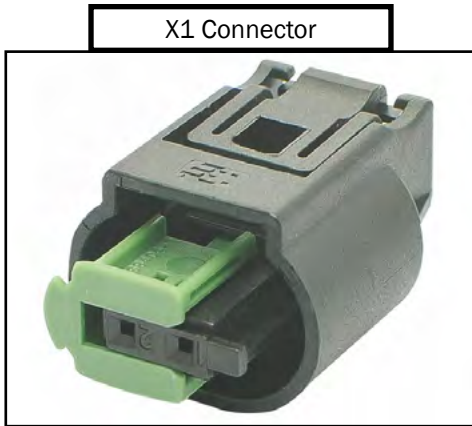

Figure 37

X1 Plug:

The X1 plug is the connector for the burner fuel pump.

Manufacturer	Part No.	Common Name
TE Connectivity	1-967644-1	Socket Housing
TE Connectivity	0965906-1	Terminal
TE Connectivity	0-967067-1	Wire Seal



Figure 38

F1 Fuse Holder:

The F1 Fuse holder, with 20A fuse.

Manufacturer	Part No.	Common Name
Packard	15300027	Female Connector
Aptiv	12129493	Terminal
Aptiv	15300014	Lock
Aptiv	15324983	Seal
Aptiv	ES10	Cover
Packard	-	20Amp Fuse (included)

Burner Wire Harness Diagram

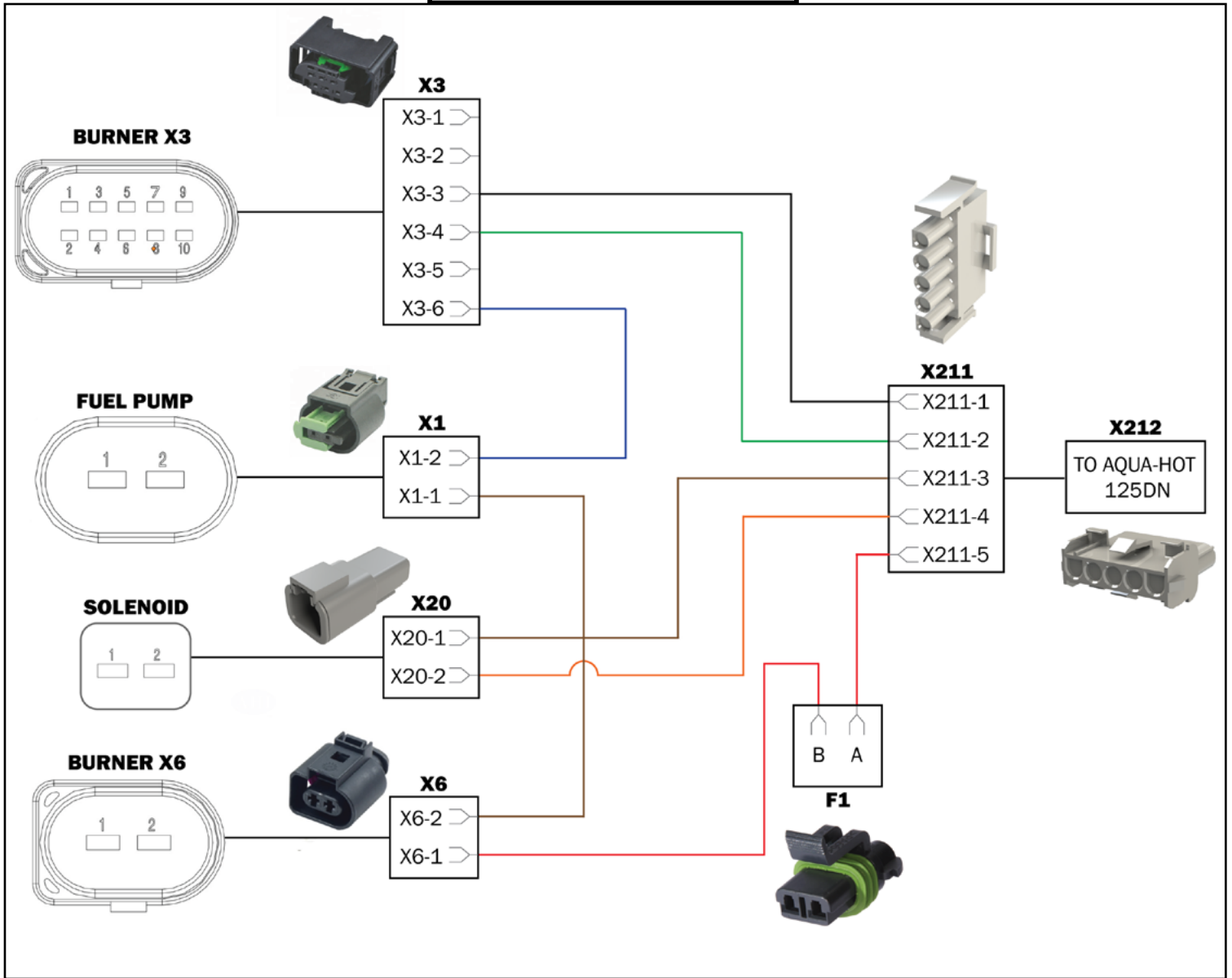

Figure 39

Burner Bottom View



Figure 40

Connecting the Burner to the Aqua-Hot

These instructions will cover the installation and connections for the diesel burner to the 125DN.

Installation Instructions

1. Mock-up the locations for the diesel burner and the Aqua-Hot within the RV to ensure that there is adequate room for access of the burner and the Aqua-Hot.
2. Verify the Aqua-Hot is secured in place.
3. Position and secure the diesel burner in place.
4. Reference the image below for the burner for the supply and return ports for the antifreeze and water heating solution.

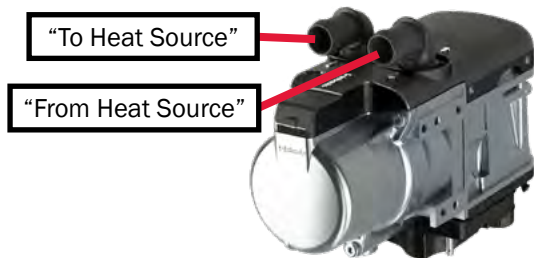

Figure 41

5. Connect the diesel burner return and supply hoses to the Aqua-Hot as indicated by the graphic below.

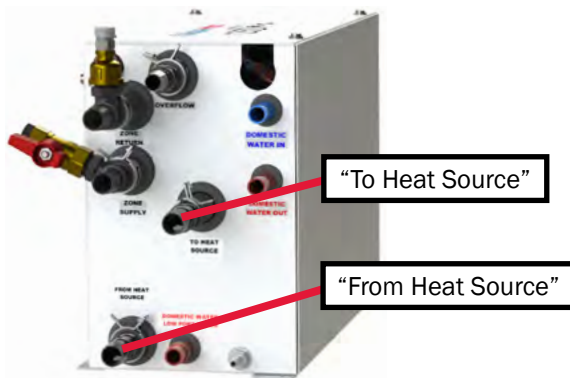

Figure 42

6. Secure the plumbing to the burner with constant tension hose clamps.



Figure 43

7. Locate the Aqua-Hot wire harness plug (Part Number ELE-102-210). The connectors for the Aqua-Hot harness and the burner harness are shown below. Reference page 18 for more information.



Figure 44



Figure 45

8. Plug in the connector X212 to the burner X211. The diagram below shows more detail.

Pin Number	Description
1	Power-On Signal
2	Heater Status Signal
3	Ground
4	High Altitude Power
5	Constant Power 12V DC (25A Max)

9. Organize and tidy the wires that lead to the burner and the Aqua-Hot to protect them from damage and short circuits.

Burner Connections

The burner comes pre-assembled, but the direction of the supply or return connectors can be modified if needed.

Please reference the instructions below and the image in Figure 46.

- The O-rings must be clean and lubricated prior to installation on the burner.
- Install the O-rings in place on the burner.
- Mount the connector housing in the retaining plate and fasten with a 15mm self-tapping screw, torque to 5 lb-ft.
- Verify the inlet and outlet ports on the burner prior to installing hoses. The correct direction of the coolant flow must be determined. The heater has flow arrows on the top (see Figure 47).
- Secure hose connections using hose clamps, tightened with a torque of 40 lb-in.

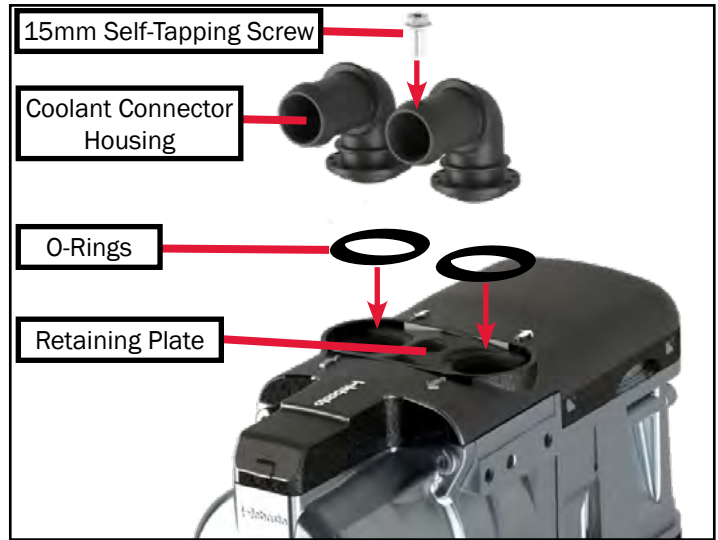

Figure 46

NOTE: When screwing on the retaining plate with the coolant connectors, do not re-cut the thread multiple times. The screw must be carefully inserted in the existing threads and screwed in by hand.

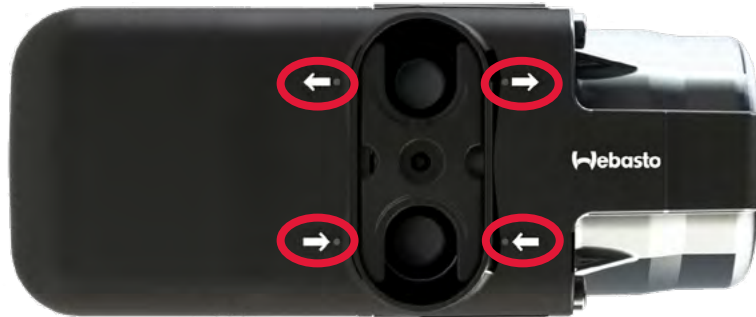

Figure 47



Figure 48



Figure 48

NOTE: The hose connector housing can be oriented either way as shown above, depending on what is necessary for proper installation of the burner and the plumbing lines.

Plumbing Requirements

The plumbing lines are how the fluid is transferred from the Aqua-Hot to the burner and back to the Aqua-Hot to transport heat to domestic water and to the interior of the RV.

Properly installing the coolant hoses to the Aqua-Hot from the burner are integral to the correct and safe operation of the heating system.

Reference the requirements below to ensure the plumbing lines are properly installed.

- Hoses used in this installation must comply with SAE 20 R3 specifications.
- The plumbing hoses should avoid any bends or dips as these can cause excess air in the lines, not allowing the flow of coolant to properly flow.
- The hose clamps must be tightened with a torque of 40 lb-in.
- Reference the plumbing diagrams below for an example of how the burner should be plumbed with the 125DN.

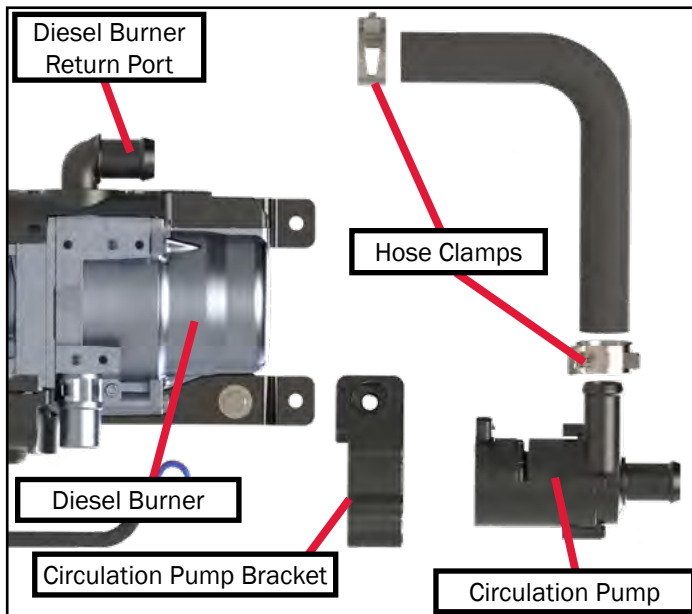

Figure 49

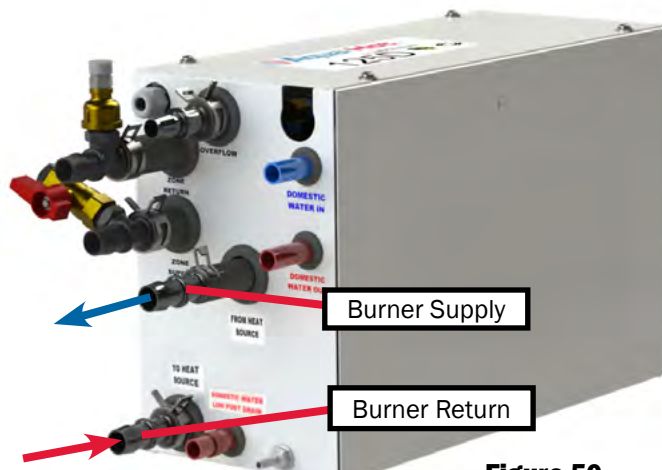

Figure 50

NOTE: This diagram below is simply a reference to show the layout and flow of the plumbing to and from the heaters. Placement may vary depending on the RV.

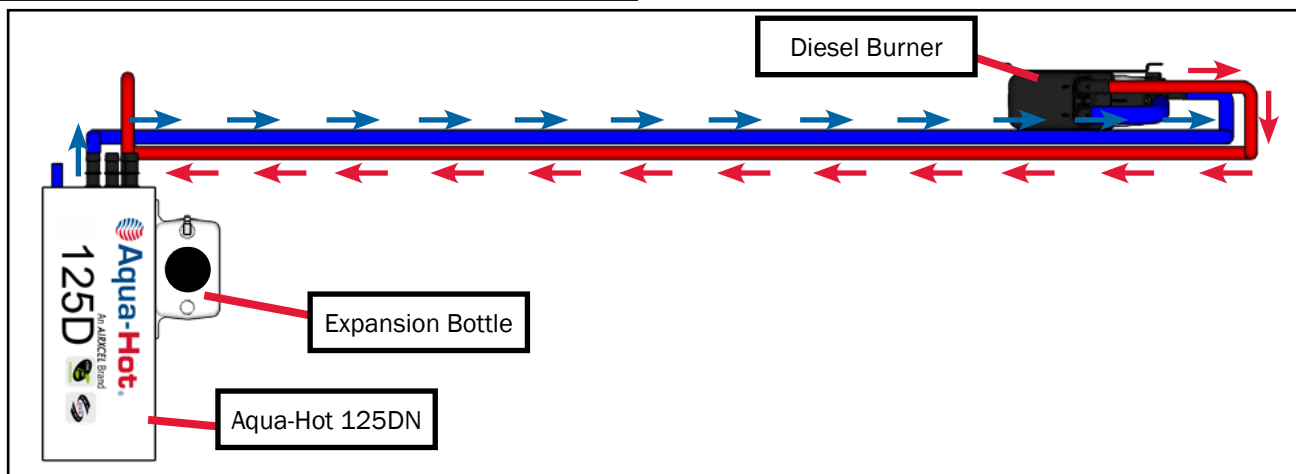

Figure 51

Wiring the Aqua-Hot

This section will introduce the basic considerations, practices, and information necessary to wire the Aqua-Hot to any relevant RV-side systems.



WARNING

Installation must be performed by a professional installer or technician as per national/local regulations.

Improper installation can cause property damage, injury, or death.

The following section will outline the basic pin out information for the two RV-side plugs (J6 and J8.)

J7 Wire insertion view shown



Figure 52

J7 Plug:

The J7 plug is responsible for managing all zone fan power connections, and boost pump supply and return.

Manufacturer	Part No.	Common Name
TE Connectivity	1-480706-0	9-Position Mate-N-Lock
TE Connectivity	350550-1	Mate-N-Lock Power Contacts

Once all the required hardware has been acquired, wire the J7 plug according to the table below. J7-9 is not used.

Pin Number	Function	Connect To
J7-1	Fan 1 Supply	Zone 1 Fans (+)
J7-2	Fan 2 Supply	Zone 2 Fans (+)
J7-3	Fan 3 Supply	Zone 3 Fans (+)
J7-4	Fan 1 Ground	Zone 1 Fans (-)
J7-5	Fan 2 Ground	Zone 2 Fans (-)
J7-6	Fan 3 Ground	Zone 3 Fans (-)
J7-7	Boost Pump Supply	Boost Pump +
J7-8	Boost Pump Ground	Boost Pump -
J7-9	UNUSED	UNUSED

J8 Plug:

The J8 plug is meant to handle the zone thermostats and House Power Sense functionality. House power sense functionality will be described in detail later in this manual.

J8 Wire Insertion View Shown

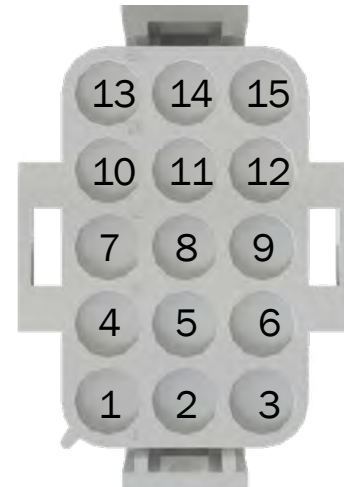

Figure 53

Manufacturer	Part No.	Common Name
TE Connectivity	1-480710-0	15 Position Mate-N-Lock
TE Connectivity	350550-1	Mate-N-Lock Power Contacts

Once the required hardware has been acquired, wire the J8 plug according to the table below. Pins J8-10 through J8-15 are not utilized.

Pin Number	Function	Connect To
J8-1	Zone 1 Thermostat In	Zone 1 Thermostat
J8-2	Zone 1 Thermostat Supply	Zone 1 Thermostat
J8-3	UNUSED	UNUSED
J8-4	Zone 2 Thermostat In	Zone 2 Thermostat
J8-5	Zone 2 Thermostat Supply	Zone 2 Thermostat
J8-6	UNUSED	UNUSED
J8-7	Zone 3 Thermostat In	Zone 3 Thermostat
J8-8	Zone 3 Thermostat Supply	Zone 3 Thermostat
J8-9	House Power Sense	12V DC Power (+)
J8-10	UNUSED	UNUSED
J8-11	UNUSED	UNUSED
J8-12	UNUSED	UNUSED
J8-13	UNUSED	UNUSED
J8-14	UNUSED	UNUSED
J8-15	UNUSED	UNUSED

J3 Plug:

The J3 plug connects to the on-board RVC system of the RV. It is a 4-pin connector with self contained power pins. See the diagram below for the crimping information for the J3 plug. Crimp these parts together using pliers.

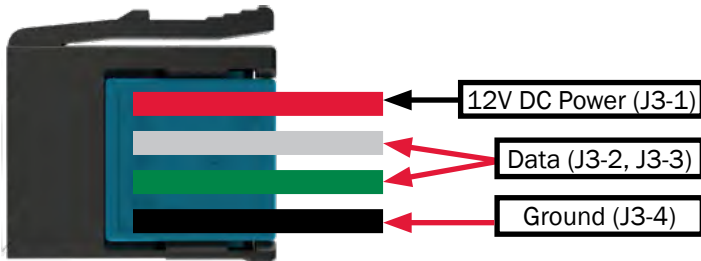

Figure 54

Manufacturer	Part No.	Description
3M	37401-2165-000 FL 100	4-Position MALE Plug
3M	37104-2165-000 FL 100	4-Position FEMALE Receptacle
General Cable	E2104S.41.02	4COND 22AWG WHT SHLD Cable

The parts listed above can be purchased from any major electronics retailer. Only the parts listed above are approved for use in the Aqua-Hot.

Pin Number	Description
J3-1	12V DC Power
J3-2	Data
J3-3	Data
J3-4	Ground

House Power Sense

Introduction:

The Aqua-Hot Controller contains within it a fail-safe functionality known as House Power Sense. This functionality serves as a live signal to the Aqua-Hot allowing it to continue operating. If power is lost to the on-board RVC network or other on-board control systems, the Controller is signaled to shut down operation until a 12V DC power signal is returned to the unit.

Wiring for House Power Sense

In order for the Aqua-Hot to function correctly, supply 12V DC power to either the J8-9 pin OR to the J3-1 pin.

In order to maintain the fail-safe nature of the House Power Sense, supply 12V DC power to the J8-9 pin OR the J3-1 pin. Do NOT supply power to both of these pins.

J8 Wire Insertion View Shown

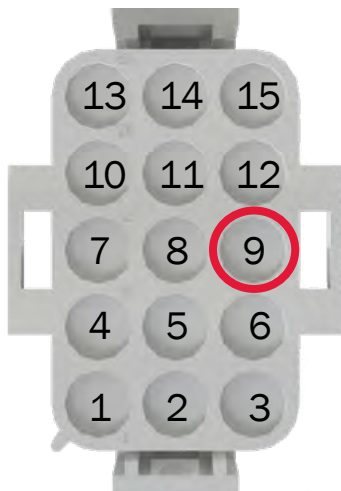

Figure 54

Wiring for Multi-Plex Systems:

When wiring for Multi-Plex Systems, route a power wire from a power connection on the RVC system to the Aqua-Hot's J3-1 pin (that is, plug J3, pin 1.) The House Power Sense will not function correctly if 12V DC power is not supplied from a device on the RVC network.

Routing the wire from the RVC network (or from an accessory on the RVC network) ensures that if the RVC network goes off-line (but the vehicle remains otherwise powered), the Aqua-Hot will not continue to operate unabated.

There are two ways to wire the House Power Sense for use with a Multi-Plex network; typical wiring case and a special wiring case.

Typical

The typical use case in wiring the House Power Sense requires a constant 12V DC signal on plug J3-1 for the House Power Sense. Plug J3 is the 4-position RVC plug. This is the easiest way to implement House Power Sense on vehicles with on-board Multi-Plex systems.

Special

If for some reason pin J3-1 cannot be supplied with power, supply 12V DC power to the J8-9 pin.

J3 Wire Insertion View Shown

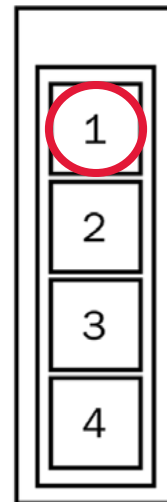

Figure 55

Connecting the 125D to 12V DC Power



DO NOT connect 12V DC power to the Aqua-Hot if the vehicle requires welding. Electrical welding will cause serious, irreversible damage to the Aqua-Hot.

The section will outline the requirements, steps, and information necessary to connect the Aqua-Hot to the vehicle's 12V DC power system. Follow all guidelines and pay attention to all notes contained herein. Failure to adhere to these guidelines can inhibit unit performance, and may cause damage to the Aqua-Hot and/or the RV.

- Installation must be performed by a qualified, professional according to current national regulations. Reference A119.2/NFPA 501C Standard on Recreational Vehicles 1993 Edition for relevant national regulatory information.
- Select the correct wire gauge for installation referencing ANSI/RVIA-LV.
- Protect the Aqua-Hot from over-current and shorting by incorporating a 20A breaker (minimum) to the Aqua-Hot's RV-side power connection.
- Acquire the relevant parts for connecting the Aqua-Hot to 12V DC power by referencing the table below.

	Deutsche	Amphenol
Pins	1060-12-0222	AT60-12-0222
Housing	DPT04-2P	ATP04-2P
Wedge	WP-2P	AWP-2P

- After crimping and assembling the power connector, connect this plug to its receptacle on the Aqua-Hot until it clicks into place.

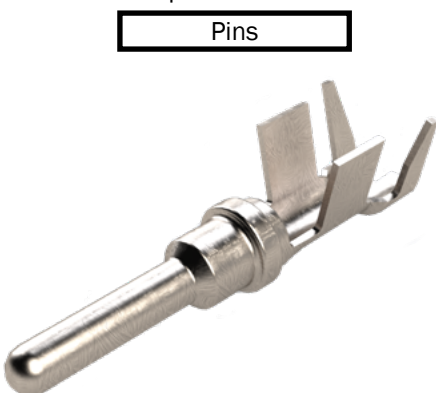

Figure 57



Figure 58

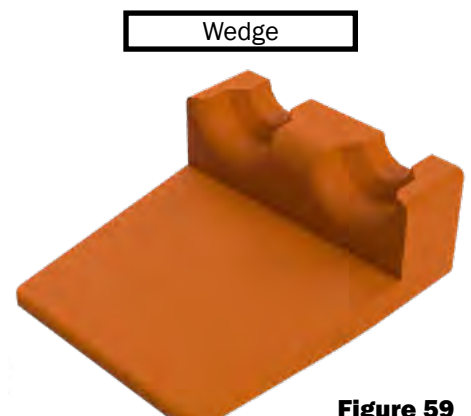

Figure 59

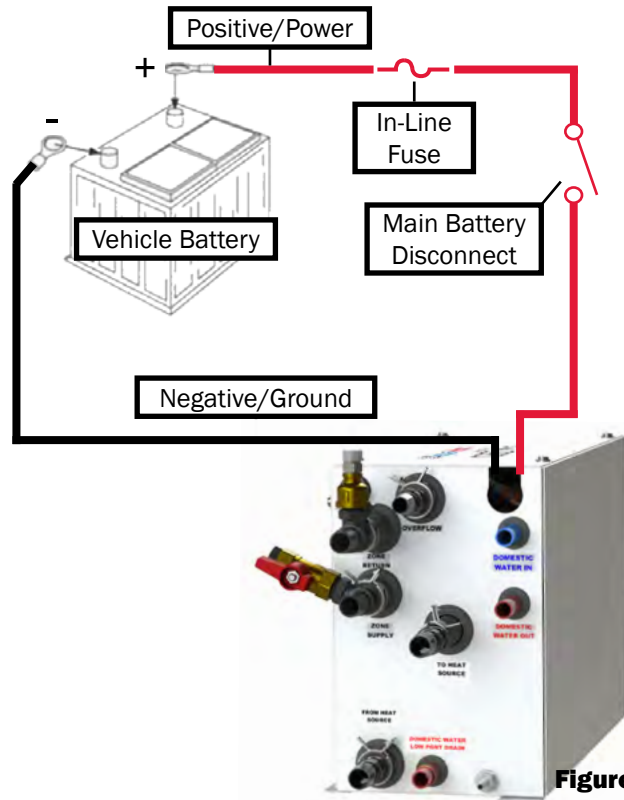

Figure 56

- The image above is simply a reference. A professional, licensed installer needs to determine the necessary components and configuration according to local codes and standards.
- The 12-volt supply to the heater must be routed directly from the battery.
- All power circuits must be protected with fuses or automatic circuit breakers.

Connecting the Aqua-Hot to AC Power

The following section will detail how to connect the Aqua-Hot to the vehicle's AC electric system. Connect the 3-pin Molex connector to the coach-side AC electric system in order to utilize the Aqua-Hot's AC heating element.

The Aqua-Hot utilizes Molex 19403 and 19045 series connectors for the AC electrical circuit. These are self-contained connectors which can be readily purchased from your choice of electronics supplier. Listed below are three different mating connections.

Self-Contained Power Connector - 2 Circuit for Solid Wire		
Size	Part Number	Housing Color
12-14AWG (2.00mm ²)	19045-1000	White
Self-Contained Power Connector - 2 Circuit for Stranded Wire		
14-16AWG (2.00mm ²)	19403-1011	Blue
12AWG (2.00mm ²)	19403-1010	Yellow

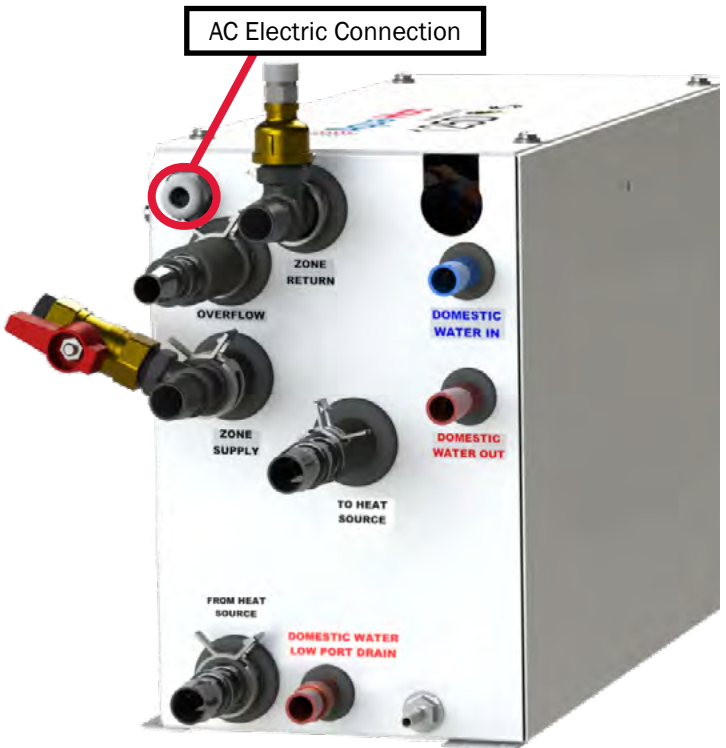

Figure 60

- Installation must be performed by a qualified professional according to current national regulations. Reference A119.2/NFPA 501C Standard on Recreational Vehicles 1993 Edition.
- The boiler must be connected to a 120V AC supply permanently and be protected with a 20A breaker (minimum). The 120V AC must be separate from 12V DC.
- It must be possible to disconnect the power to the boiler, either an easily accessible plug or a circuit breaker.
- Please refer to the schematic on page 53.

Molex 19045-1000

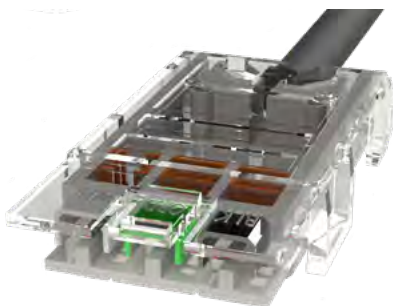

Figure 61

Molex 19403-1010

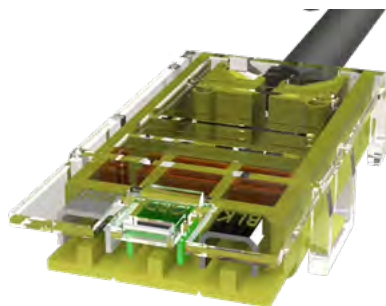

Figure 62

Molex 19403-1011

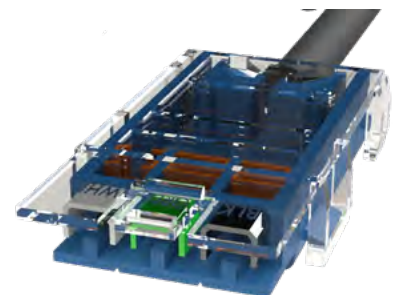

Figure 63

Installation Requirements

Cozy heat exchangers can be mounted in one of two configurations: either flat on the ground, or vertically. Reference Figure 64.

- Supply ventilation cross-sectional area of at least 29in² (74cm²) must be supplied to each heat exchanger.
- Do not supply heat exchangers air which is drawn from the bay areas.
- Return air should be drawn from the same room the heat exchanger is heating.
- The anti-freeze and water heating solution must flow in through the bottom of the heat exchanger, and out the top (reference Figure 77).
- The Aqua-Hot 125D is designed to work with up to 3 thermostatic heating zones.



Figure 64

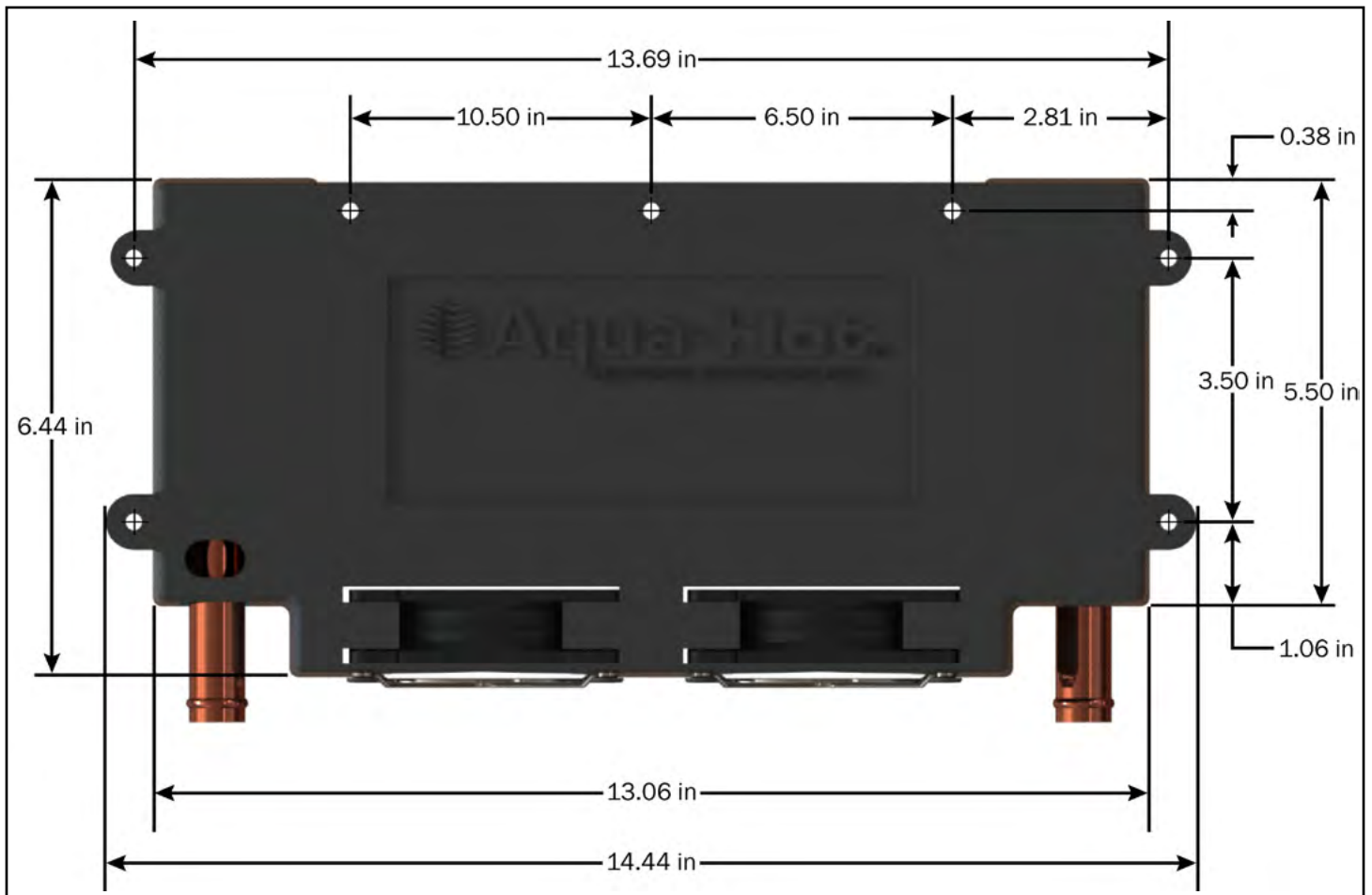

Figure 65

Heat Exchanger Locations and Clearances

- Position the heat exchangers so that even heat is distributed throughout the RV interior.
- The first heat exchanger on the loop will output the most interior heat.
- It is best practice to place the heat exchanger in an area where it can be easily accessed for maintenance.
- Place the heat exchangers as close to the floor as possible for best performance.
- If a heat exchanger is kept in the fresh water storage bay, then the last heat exchanger in the coolant loop should be used.
- The heating air supply may be fresh or recirculated air that is drawn from a clean area not likely to be contaminated.

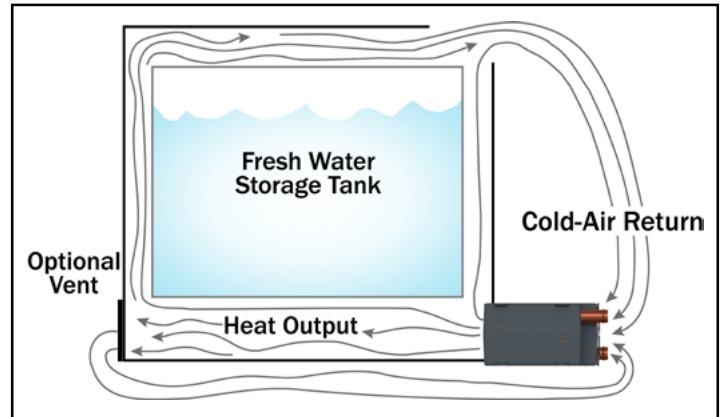

Figure 67

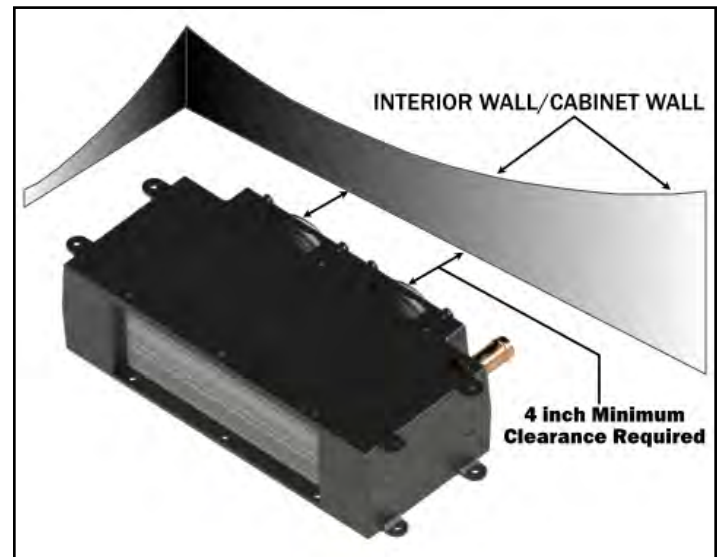

Figure 68

NOTICE

Aqua-Hot advises against placing a heat exchanger on the slide-out section of any vehicle due to the high probability of damage occurring to the heating loop from moving parts.

Mounting the Heat Exchangers

1. Cut out a 2.5" x 10" (7cm x 26cm) opening for each heat exchanger outlet and cold-air return grate as shown in Figure 64.
2. Mount each heat exchanger permanently into place. There are 4 tabs on both sides - see Figure 77.
3. Install the hot-air outlet and cold-air return grate.

A minimum of supply ventilation cross-sectional area of at least 29in² (74cm²) must be supplied to each heat exchanger.

If the toe-kick area is inadequate to house a heat exchanger for regular installation, a plenum assembly may be purchased to redirect air via ducting. Refer to Figure 71.

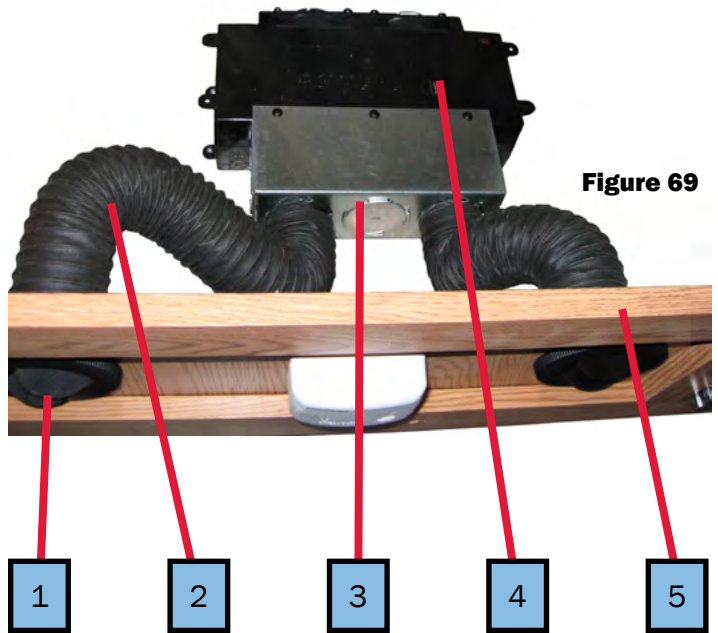

Figure 69

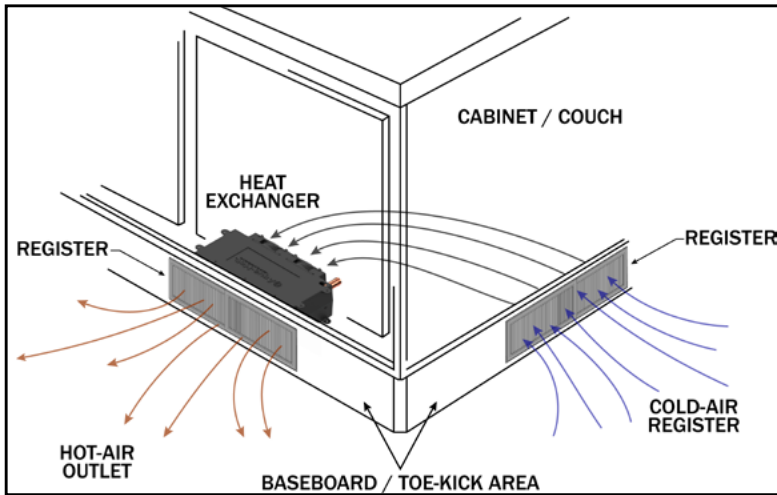

Figure 70

1. Hot Air Outlet Vent
2. Air Ducting Hose
3. Plenum
4. Cozy Heat Exchanger
5. Toe Kick Board

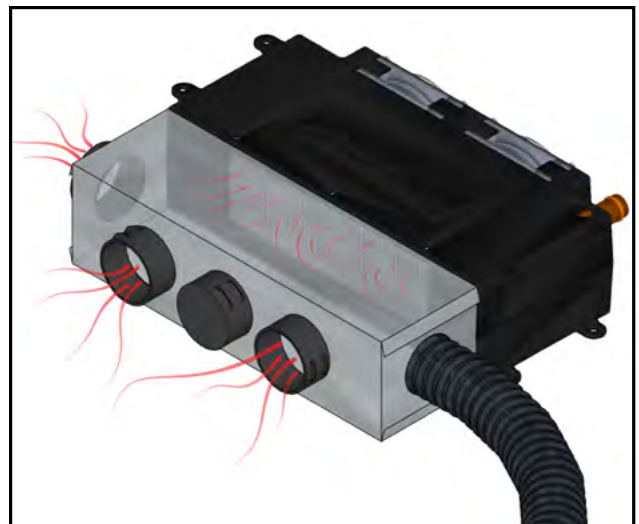

Figure 71

Wiring the Heat Exchangers

This section will explain in detail how to wire the heat exchangers for optimal functionality. Do not deviate from these guidelines. If a deviation is required, contact Aqua-Hot Heating Systems prior to installing these exchangers for express permission to proceed with modifications.

1. Wire each heat exchanger (in a thermostatic zone) in parallel to one another as shown in Figure 74.
2. Wire each heat exchanger independently to the J7 plug of the unit controller.
3. Pin-out information is shown below.

NOTE: Quiet-mode functionality of the new controller requires that the heat exchangers be wired directly into the controller.

J7 Wire insertion view shown



Figure 72

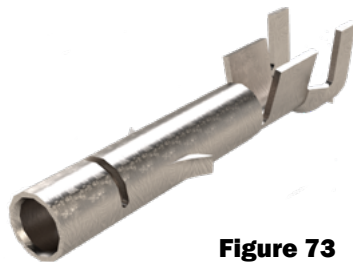

Figure 73

Thermostatic Zone Number	Supply (+) Pin Number	Ground (-) Pin Number
1	J7-1	J7-4
2	J7-2	J7-5
3	J7-3	J7-6

Connector Part Numbers

Part Number	Manufacturer	Description
1-480706-0	TE Connectivity	J7 Plug Housing
350550-1	TE Connectivity	J7 Socket Terminal

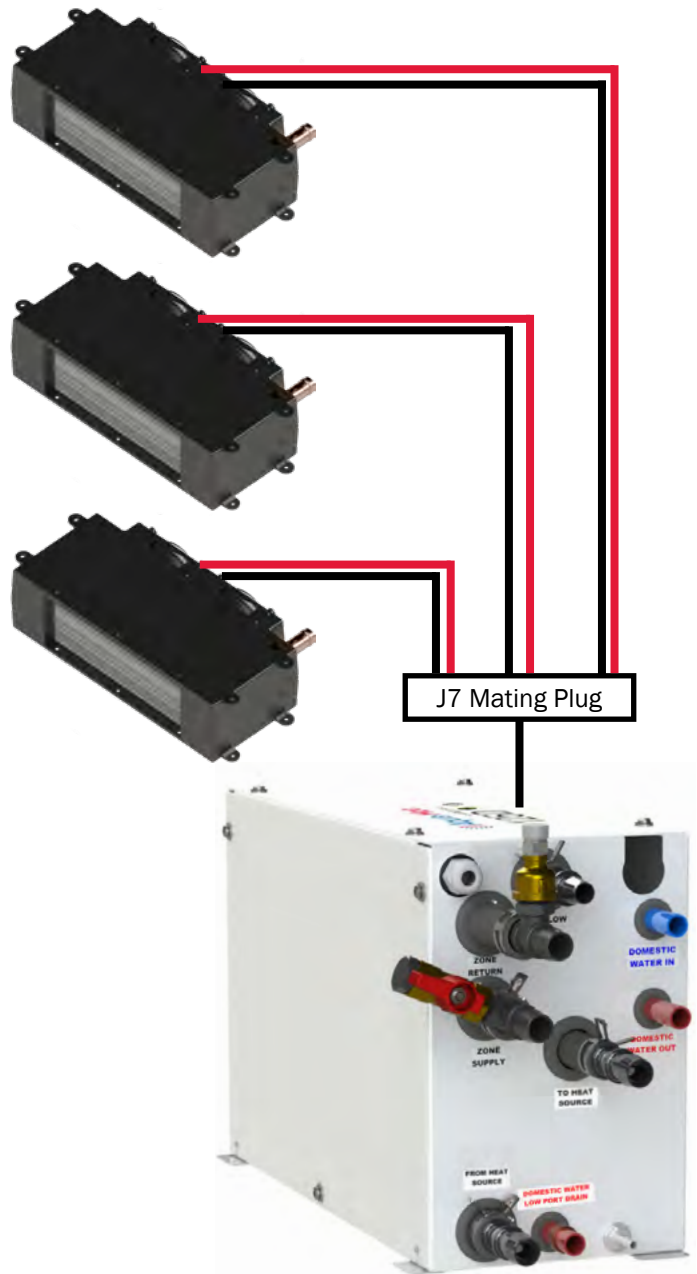

Figure 74

NOTE: The 125D can have up to 3 individual, thermostatic heating zones. The heat exchangers in different zones are wired to a different set of pins of the J7 plug.

Plumbing the Heating Zone

The following guidelines should be used when planning the coolant loop for the heating zone. The 125D requires a single fluid zone. The order of the heat exchangers should consider priority on the loop. Failure to adhere to these installation principles can hinder the operation of the heat exchangers.

- All plumbing should be installed as flatly as possible.
- Extreme rises in height should be avoided to avoid any potential air traps.
- Use 5/8" ID plumbing lines, 3/4" SAE J20 type coolant hose, heater hose, or PEX tubing for the single heating loop.
- Use wide-sweeping elbows or "bend supports" whenever the plumbing lines may be susceptible to kinking.
- Plumbing lines should be run in areas where there is no reasonable possibility that they can be pinched off or damaged under normal operating conditions.
- Secure all lines where necessary and apply protective shielding in areas where chafing may occur.
- Rubber coated/closed-type clamps are recommended when securing the plumbing lines.
- Inlet and outlet plumbing lines can be installed with a straight fitting or an elbow.

Instructions:

1. Layout the plumbing lines for all heat exchangers (see the example in Figure 78).
2. Label each line and designate as an outlet or an inlet line.
3. Connect and clamp the outlet line from the heater to the lowest port (inlet port).
4. Connect and clamp a line from the first heat exchanger's highest port, and connect the other end to the next heat exchanger's lowest point.
5. Connect each additional heat exchanger in the same arrangement.
6. Connect and clamp the inlet line from the heater to the highest port on the last heat exchanger to complete the heating loop.



Figure 75

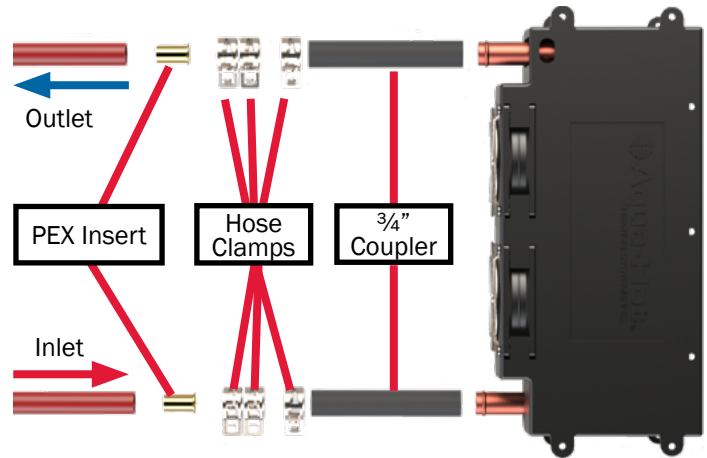

Figure 76

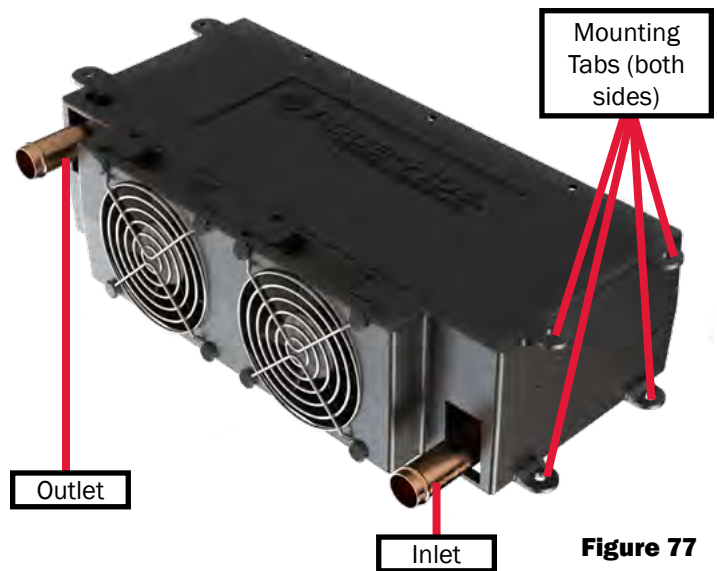

Figure 77

NOTE: This diagram is simply a reference to show the layout and flow of the plumbing to and from heat exchangers. Placement and quantity may vary depending on the RV.

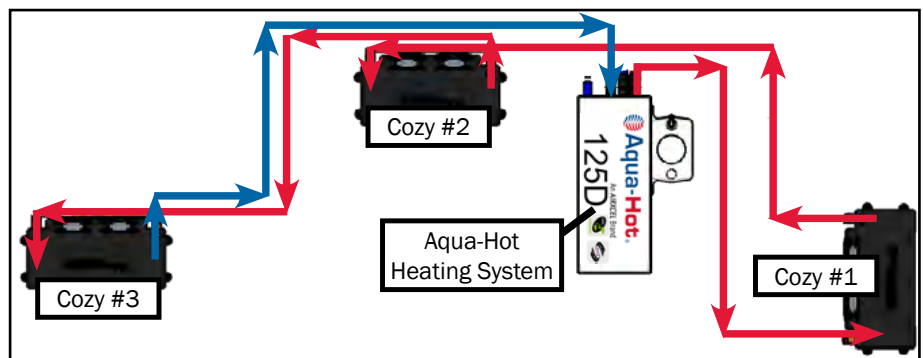

Figure 78

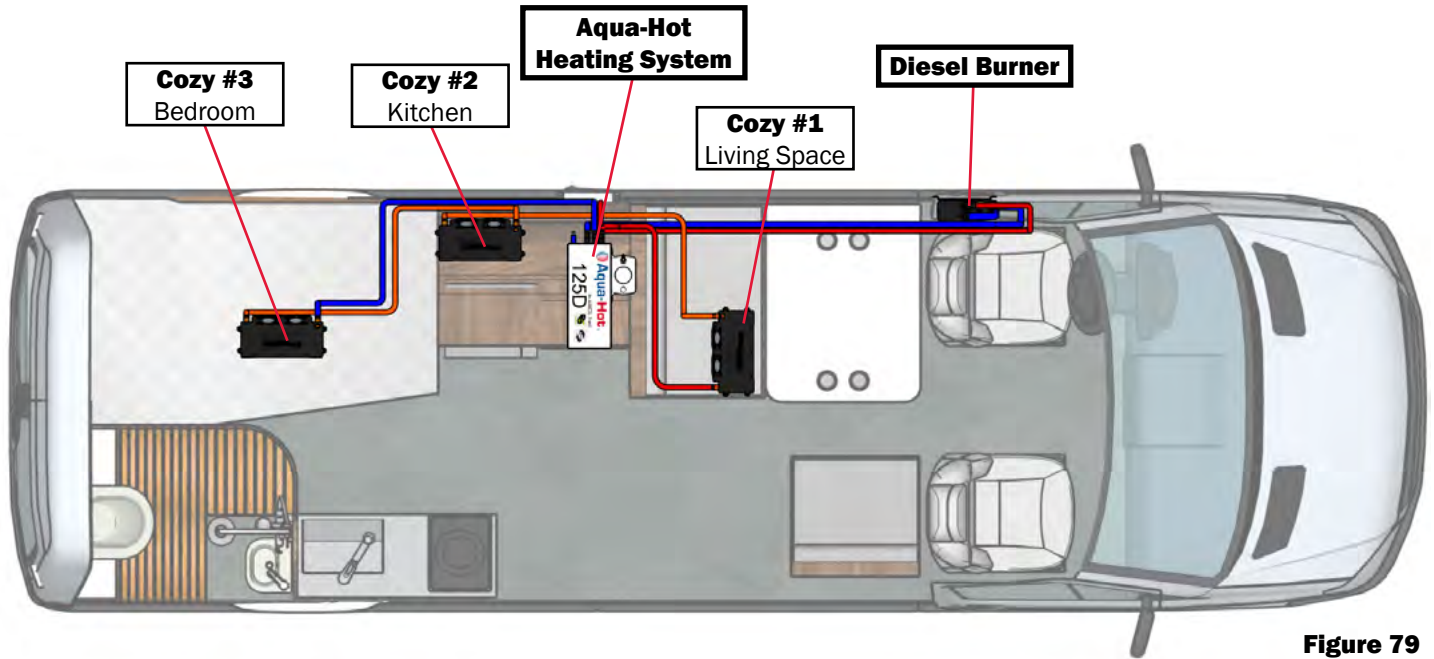

Figure 79

NOTE: This is just a sample for the layout of the diesel burner with the Aqua-Hot and heat exchangers. Actual placement may vary on the individual design of the RV. For questions or assistance, contact Aqua-Hot at 574-AIR-XCEL (574-247-9235).

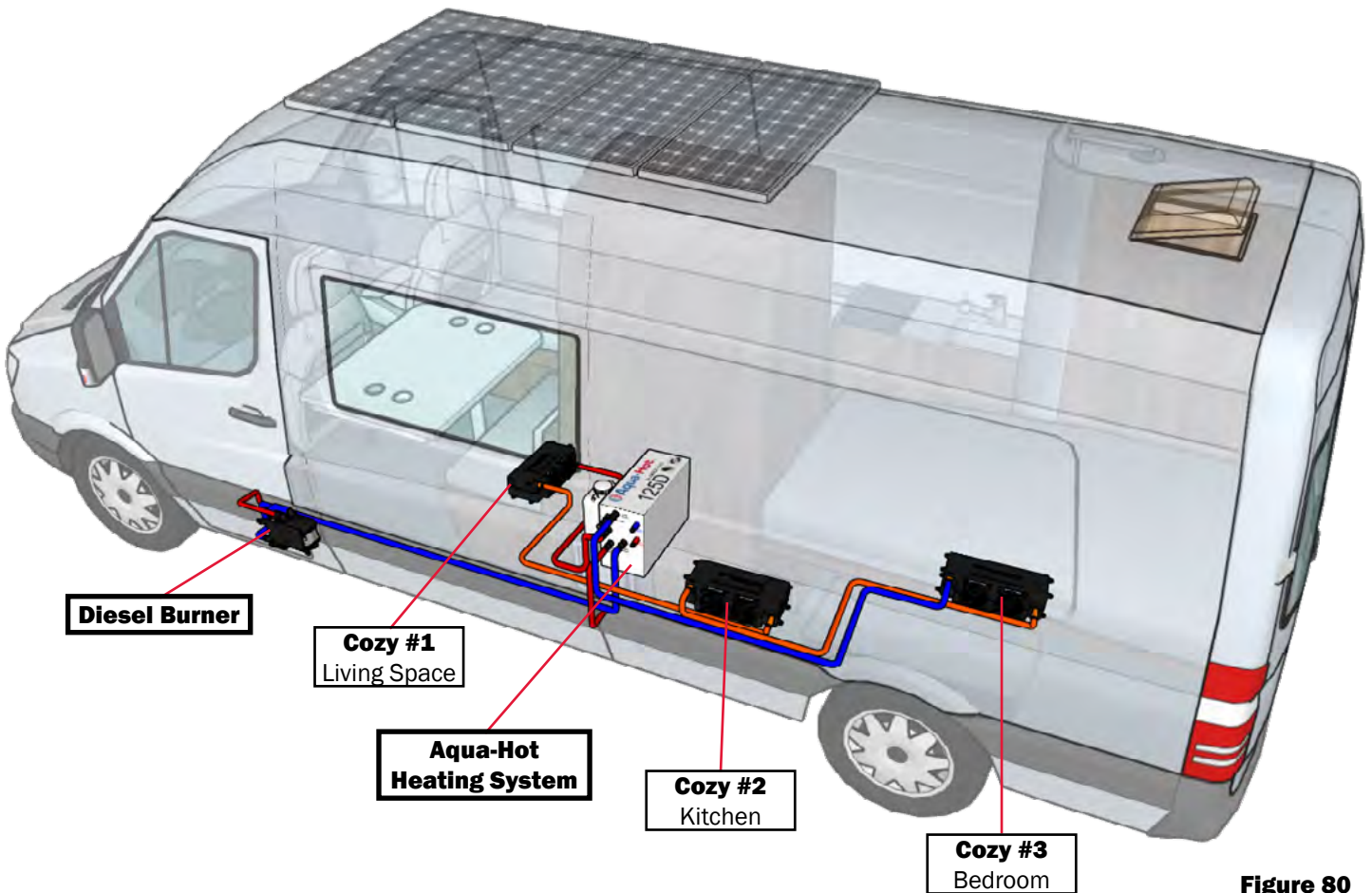

Figure 80

Domestic Water System Requirements

- Reference A119.2/NFPA 501C Standard on Recreational Vehicles 1993 Edition for relevant regulatory information regarding the design of Domestic Water Systems.
- The Aqua-Hot is equipped with a pressure relief valve and a tempering valve in order to provide safe hot water without chance of scalding or an over-pressurized system.
- Plumb the domestic water system according to Figure 82.

NOTE: The Aqua-Hot Domestic Water System is rated for a water flow of 0.8 GPM. It is not recommended to modify the water flow. This can cause an over-pressurized system or lack of consistent hot water.

NOTE: Extended exposure to household bleach will corrode the components of the Aqua-Hot that will potentially dramatically shorten the operational lifetime of the Aqua-Hot. Under no circumstances is the Aqua-Hot to be exposed to household bleach for extended periods of time. This type of damage is not covered by the Aqua-Hot warranty.

Plumbing the Domestic Water System

The Aqua-Hot is also able to provide domestic hot water while the boiler tank is up at operating temperature. Activate the external diesel burner to provide adequate heat for hot water needs. The electric element will only provide light duty hot water.

The tempering valve is integrated into the cabinet of the Aqua-Hot, and is set upon departure from the Aqua-Hot factory. So long as the tempering valve is not modified, it will provide hot, non-scalding water.

Instructions

1. Locate the domestic cold water inlet (blue PEX tube) and connect it to the vehicle's domestic cold water system.
2. Locate the domestic hot water outlet (red PEX tube) and connect it to the vehicle's domestic hot water system.



Figure 81

⚠ DANGER

Risk of Severe Burn or Death from Scalds. Water temperature over 51°C (123.8°F) can cause severe burns instantly or death from scalds. See instruction manual before setting temperature at water heater. Feel water before bathing or showering. Temperature limiting valves are available, see manual.

WARNING:
HOT WATER CAN PRODUCE 3RD DEGREE BURNS
- IN 6s at 60°C (140°F)
- IN 30s at 54°C (129.2°F)
WATER DELIVERY TEMPERATURE MIXING VALVE WAS FACTORY SET AT 49°C (120.2°F).
CONTACT QUALIFIED SERVICE PERSONNEL FOR ADJUSTMENTS.

Risque de brûlures graves ou la mort de brûlures. De l'eau à une température au-dessus de 51 °C (123,8 °F) peut ébouillanter et causer instantanément des brûlures graves allant jusqu'à la mort. Consultez le manuel d'instructions avant de régler la température du chauffe-eau. Vérifiez la température de l'eau avant de prendre un bain ou une douche. Des soupapes de limite de température sont disponibles, voir le manuel.

AVERTISSEMENT:
L'EAU CHAUDE PEUT PRODUIRE DES BRÛLURES DE TROISIÈME DEGRÉ
- EN 6s à 60°C (140°F)
- EN 30s à 54°C (129.2°F)
LA VANNE DE MÉLANGE DE TEMPÉRATURE D'ALIMENTATION EN EAU A ÉTÉ RÉGLÉE EN USINE À 49 °C (120.2 °F).
CONTACTER DU PERSONNEL DE SERVICE QUALIFIÉ POUR LES ADJUSTEMENTS.

LDE-003-260

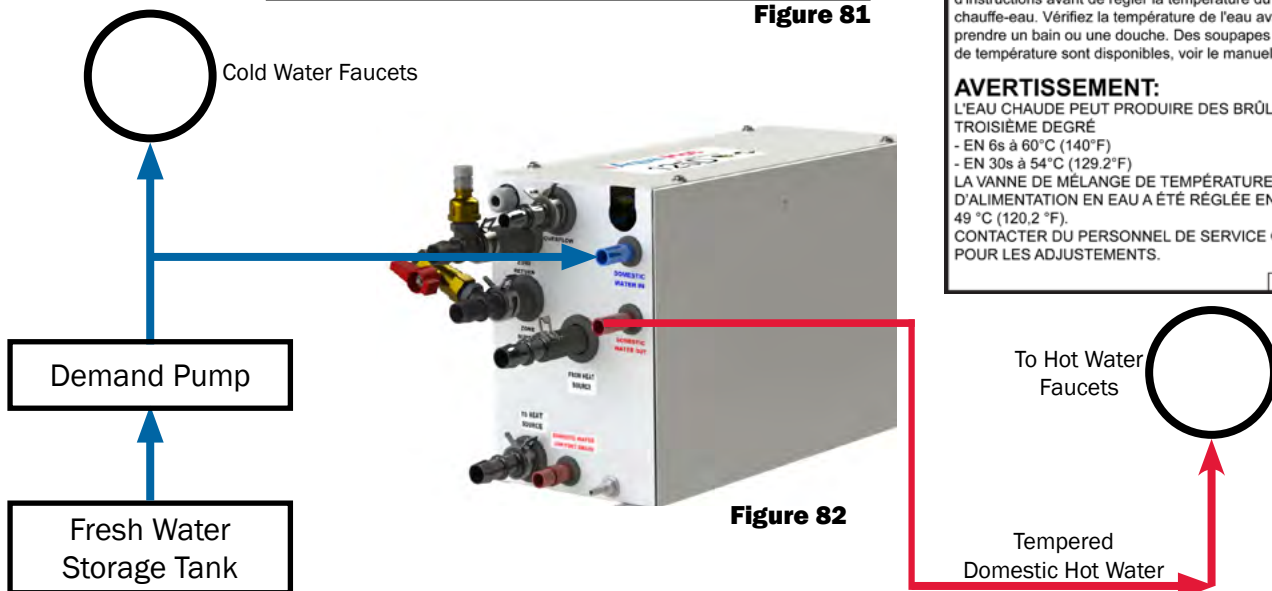

Figure 82

Mounting the Aqua-Hot LCD



Figure 82

Mounting Procedure:

1. Select a location within the RV.
2. Cut a 3.06" x 5.15" hole in the RV wall.
3. Route the corners of this cutout with a ¼" (64mm) diameter bit.
4. Using four countersunk #4 screws, secure the LCD bracket into place over the cutout just made.
5. Connect the RVC cable to the back of the LCD screen.

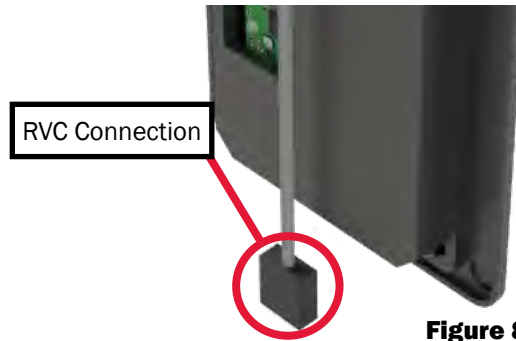

Figure 83

6. Snap the LCD screen into the mounting bracket.

Introduction:

This following section will explain in detail how to mount the Aqua-Hot LCD on the interior of the RV.

Mounting Considerations:

- Purchase the necessary RVC connection parts according to the table below.

Manufacturer	Part Number	Common Name
3M	37104-2165-000 FL 100	4-pin RVC Male Connector
General Cable	E2104S.41.02	RVC Communication Cable

- Route the 15' RVC cable from the intended mounting position of the LCD to the Aqua-Hot Controller.
- The LCD screen is powered via the RVC cable which connects directly to the Aqua-Hot Controller, or via an on-board RVC network.
- "DATA ONLY" RVC cable configurations are not compatible with the LCD screen.
- The screen requires at least ¾" of backside clearance to allow room for cables and connections.

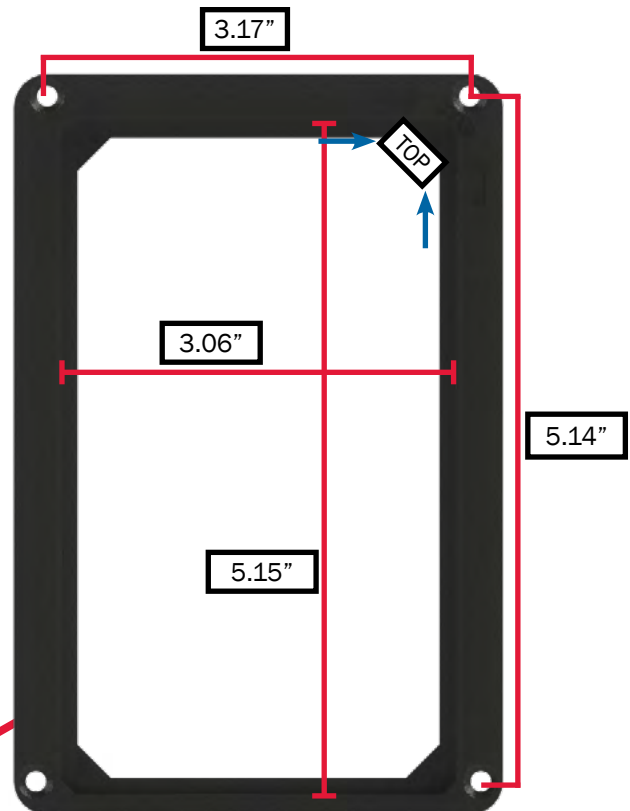

Figure 84

NOTE: Please note that the LCD Screen mounting bracket may only be mounted in this configuration as shown in Figure 84. The screen will not fit in properly any other way.

Operating the LCD

Introduction:

This document will outline the basic operating instructions for the Aqua-Hot LCD Screen.

Climate Pages:

The climate pages are for all intents and purposes the “Home” of the LCD screen. From here, the end-user will select their interior temperature set-points, activate or deactivate the diesel burner and/or the electric element.

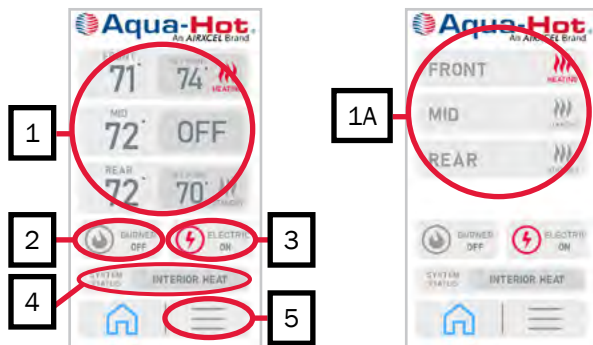

Zone Control (1):

Precise zone control display will differ depending on the type of zone thermostats used within the RV.

Section 1A demonstrates the appearance of the zone control section when ON/OFF thermostats are used within the RV. In this use-case, these buttons serve only as ON/OFF toggle switches.

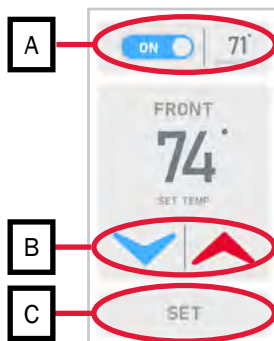

Tapping on one of the zones shown above will display a new screen where the interior temperature can be set.

Section A:

This section shows the current zone temperature (shown as 71°F in the example above) as well as a button to turn the zone on or off.

If the zone temperature is set, but this item is not set to ON, the zone heat exchanger will not activate.

Section B:

These arrows are used to increase or decrease the desired set-point temperature of the zone thermistor.

Section C:

After the desired temperature set-point has been selected tap “SET” on the LCD to set that temperature. The Aqua-Hot will now work to maintain this interior temperature, and the screen will return home.

External Diesel Burner Activation (2):

The external diesel burner of the Aqua-Hot can be activated by tapping on the “burner” item on-screen. The diesel burner has two modes: ON and OFF.

ON:

While ON, the Aqua-Hot diesel burner will work to maintain a tank temperature of 180°F and a minimum tank temperature of 160°F.

OFF:

While off, the diesel burner will not serve to provide any heat to the boiler of the Aqua-Hot whatsoever.

Electrical Element Activation (3):

Similar to the external diesel burner, tapping this button will signal to the controller to activate the AC electric relay, energizing the 1500W electric element within the Aqua-Hot.

ON:

While ON, the electric element will work to maintain a tank temperature of 180°F, with a minimum tank temperature of 165°F.

OFF:

While off, the element will not serve to provide any heat to the boiler of the Aqua-Hot whatsoever.

System Status (4):

This item will indicate the current operational status of the Aqua-Hot. If any faults have triggered, those will be displayed here.

During normal operation, this should display either INTERIOR HEAT or HOT WATER relating to the priority and position of the 3-way valve.

While in INTERIOR HEAT mode, the 3-way valve is oriented so as to circulate heated antifreeze and water solution through the heating zones of the RV.

While in HOT WATER mode, the 3-way valve is oriented so that the heated antifreeze and water solution is circulated immediately back into the boiler tank. This is known as “stirring” the tank, and it is done to provide as much heat as possible to the domestic water line while water is flowing.

Module Options (5):

Tapping on the module options screen (the 3 lines on the bottom right of the home screen) will display the screen shown to the left. This is known as the Module Options screen. From here, it is possible to access unit diagnostics, activate Quiet Mode, change the temperature units, adjust screen brightness, and unit timeout.

Screen Timeout (A):

The screen timeout item sets the amount of time required to allow the screen to shut-off when idle.

Screen Brightness (B):

This setting changes the screen brightness.

Unit of Measurement (C):

This setting will change the display units of the Aqua-Hot. Either Fahrenheit or Celsius can be selected.

Aqua-Hot Diagnostics (D):

Tapping on this element will direct you to the Aqua-Hot’s built-in diagnostic, testing, and troubleshooting tools.

Quiet Mode (E):

This option toggles the Aqua-Hot’s quiet mode. Quiet mode is a setting where the speed and output of the heat exchanger fans is reduced to 80%. This is done to reduce noise of the heat exchangers.

Please note that this feature must be activated and deactivated as needed.

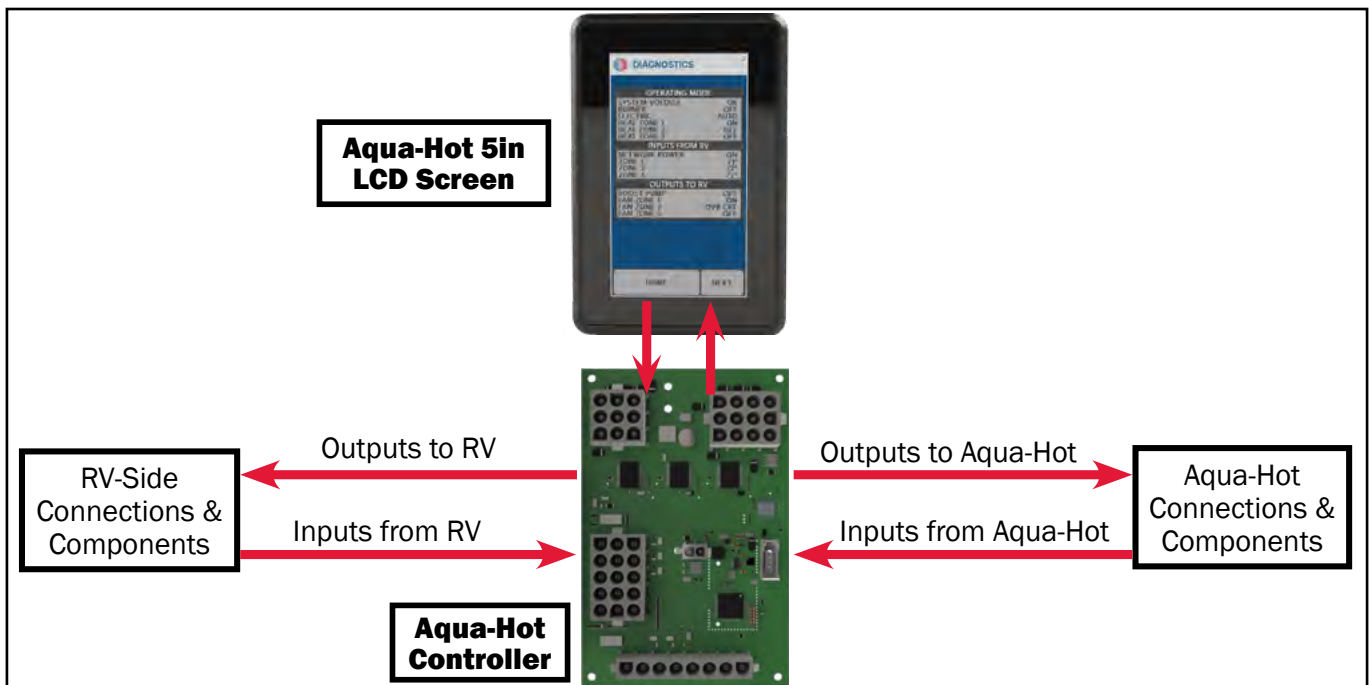
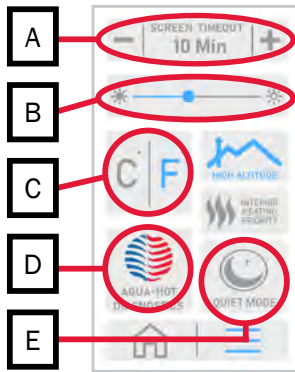

Figure 85

Configuring the Zones

Introduction:

Once the heat exchangers and thermostats have been wired to the Aqua-Hot, the Controller must be configured in order to correctly manage these zones.

Configuration:

In order to configure these zones for first use, locate the Aqua-Hot LCD screen and navigate to the Aqua-Hot Diagnostics section.



After holding the serial number section above, you will be presented with an options panel like the one shown below.

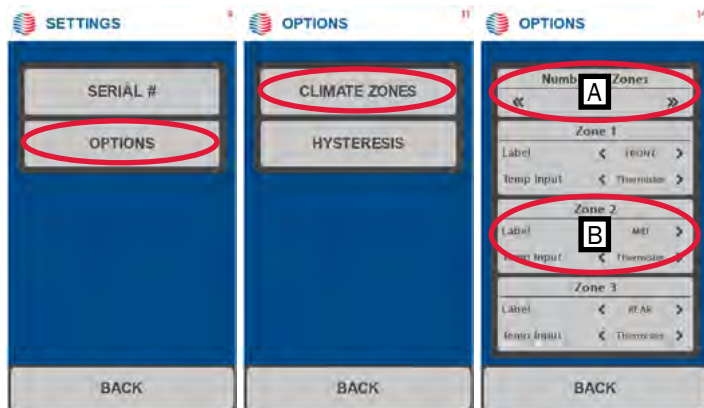

Tap OPTIONS, and then CLIMATE ZONES to access the climate zone configuration sub-menu.

Changing Zone Settings:

Once the Climate Zone section has been accessed, the information below will explain how to correctly configure the zones.

Number of Zones (A):

The Aqua-Hot can control between 1 and 3 heating zones within the RV. Modifying this will set the Controller to manage 1, 2, or 3 heating zones.

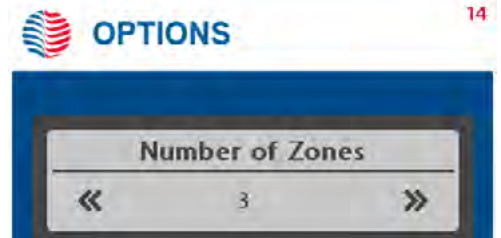

Zone Settings (B):

Zone settings will change the way each zone is labeled on the home screen of the LCD, as well as the type of thermostat used in the RV interior.

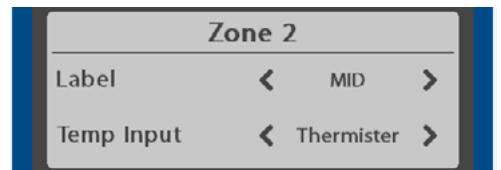

Modifying "Temp Input" will change the type of signal that is expected by the Controller.

- Set to "Thermistor" if an interior thermistor is to be used.
- Set to "Thermostat" if a traditional ON/OFF thermostat is to be used.

Modifying "Label" will change how the zone is displayed. There are three choices; Front, Mid, and Rear which correspond to the zones within the RV. See example below.



Filling the Aqua-Hot

Before the first activation of the Aqua-Hot, fill the unit with antifreeze and water heating solution. Without the solution present, the Aqua-Hot will not operate, it will not deliver hot water, and it will not deliver heat. Follow the directions below to fill the Aqua-Hot with antifreeze and water heating solution.

In order to provide the best freeze protection, boil-over protection, anti-corrosion, and rust protection, a mixture of 50/50 Ethylene Glycol antifreeze and distilled water is recommended. The Aqua-Hot 125D boiler tank holds approximately 1.8 gallons.

The mixture may be modified to provide the most adequate freezing, boiling, and rust/anti-corrosive protection. A 50/50 mixture of **Ethylene Glycol** and distilled water has a freeze point of approximately -35 °F and a boiling point of approximately 223 °F. Reference page 55 for measuring the antifreeze mixture with a refractometer.

NOTE: The expansion bottle will need to be elevated higher than the Aqua-Hot unit. Once the fill and purge procedures are complete, the expansion bottle can be properly mounted to the side of the Aqua-Hot.

Fill Instructions:

1. Locate the following items:
 - Exterior fluid pump (a diaphragm pump if possible)
 - The Aqua-Hot fluid expansion bottle
 - A bucket or pale
2. Locate the glycol product which is to be used in this heater.



WARNING

Make sure to select the correct glycol antifreeze product for the external heating source. Failure to select the correct product could seriously damage the external heat source.

3. Fill the bucket with the antifreeze and distilled water solution.
4. Locate the fluid fill port (shown in Figure 87).
5. Ensure that the fluid expansion bottle is connected to its port on the Aqua-Hot, but must be elevated higher than the Aqua-Hot unit.
6. Connect the external fluid pump to the fluid fill port.
7. Place the intake hose of the external pump in the receptacle which contains the heating solution.

8. On the LCD screen, navigate to the TESTING page, turn on the pump, and set the 3-way valve to “HOT WATER”.

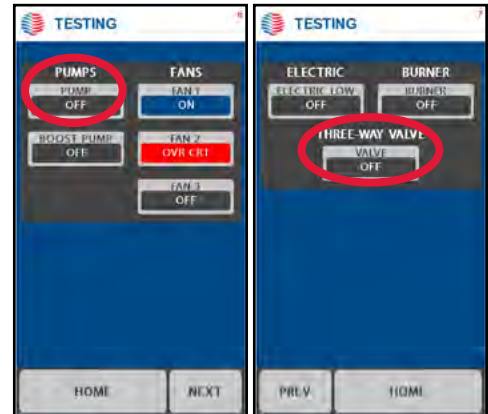

Figure 86

9. Activate the supply pump, open the fluid fill valve, and fill the unit while paying attention to the fluid expansion bottle. Allow this pump to run until the fluid level in the expansion bottle reaches the “COLD” mark.
10. Once the “COLD” mark has been reached, close the fluid fill valve and deactivate the external fill pump.
11. Remove the external fluid fill pump.
12. Proceed to the next page to purge the zone before attempting to start the unit.

Ethylene Glycol												
Freeze Point (°F)	32	25	20	15	10	5	0	-10	-20	-30	-40	-50
Concentration (%)	0	10	16	21	25	29	33	39	44	48	52	56

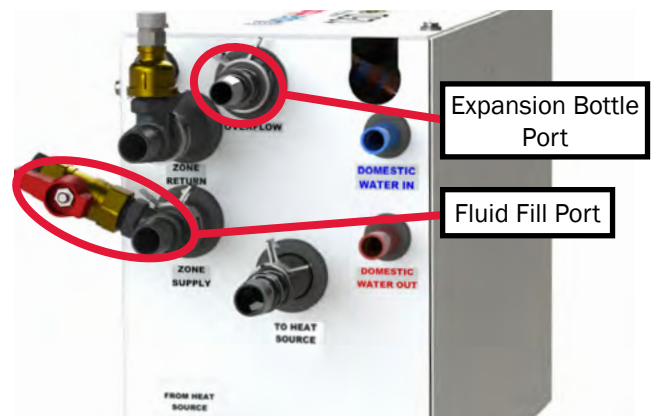

Figure 87

Purging the Interior Heating Loop

In order to provide interior heat to the vehicle, antifreeze and water heating solution is circulated within an interior “heating loop” which distributes heat throughout the RV. During installation, it is possible that air may become trapped within the heating loop and hamper unit performance.

Follow this procedure to purge any air from the interior heating loop.

Please note that if an RVC or multiplex system is used in lieu of the Aqua-Hot display, you must contact the manufacturer, or connect a display to the on-board RVC network to perform this procedure.

Purge Procedure:

1. Locate the fluid expansion tank of the Aqua-Hot. As any air is purged, it will exit through to this expansion bottle.
2. Locate a gallon of the antifreeze and water heating solution. This will be used to top-off the fluid expansion bottle as air is purged from the system.
3. Locate the Aqua-Hot 5in. LCD screen. This display may be mounted in a location away from the Aqua-Hot. Contact the vehicle manufacturer for assistance in locating this display.
4. Tap the screen to wake the display.
5. First tap the three lines at the bottom right of the screen, then tap “AQUA-HOT DIAGNOSTICS”.

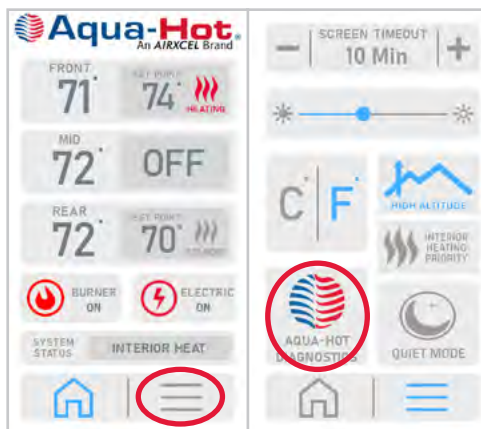

Figure 88

6. Tap “TEST” on the display to access the testing functionality.
7. You will now be displayed the testing screen.

8. Tap “PUMP” to activate the fluid circulation pump, and if applicable, “BOOST PUMP” to activate the zone boost pump.

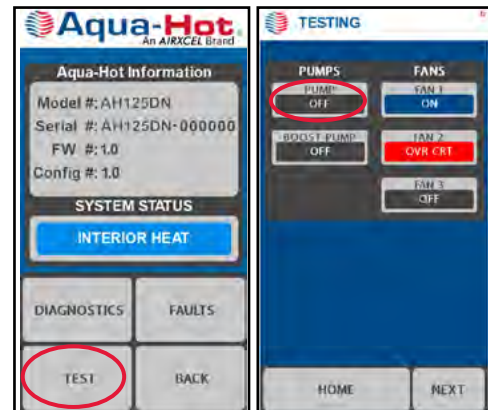



Figure 89

9. These pumps will run for a maximum of five minutes. Re-activate as necessary until they are run for at least twenty minutes.
10. Refill the fluid expansion bottle as necessary to keep it at the “COLD” line.
11. Once this process is complete, mount the fluid expansion bottle in its permanent location.

Fuel Supply

 **WARNING**

Failure to follow instructions on the fuel delivery system can cause damage to the Aqua-Hot 125DN, the diesel burner, or the RV. It may cause serious personal injury. Please follow instructions carefully.

Fuel System Requirements

- The diesel fuel supply should be drawn directly from the vehicle's main fuel tank if applicable. A separate fuel tank may be installed if necessary.
- The fuel tank should be equipped with a dedicated fuel pick-up pipe.
- Use the provided 5mm x 1mm fuel line with the included couplers and clamps.
- The fuel line must be kept as short as possible. The total length of the fuel line should not exceed 39 feet.
- The fuel line should be laid out as flatly as possible, avoiding extreme rises in height to eliminate any air traps.
- Make sure the fuel standpipe does not impair the operation of the vehicle's fuel delivery or fuel gauge in any operating mode.
- The fuel standpipe must be positioned vertically and the end should sit at least 1 in above the tank bottom.
- The high altitude bypass is installed to regulate the fuel pressure when the RV is at altitudes above 5,000 ft. This allows for proper burner operation, less carbon build-up, and less emissions.

Fuel Standpipe Installation

1. Drill a 1 in hole through the top of the fuel tank.
2. Remove sharp pieces and smooth edges with sandpaper or an emery cloth.
3. Determine the length of the standpipe so the end is at least 1 in above the bottom of the fuel tank.
4. Cut off excess standpipe at a 45° angle, remove any sharp edges.
5. Loosely assemble parts.
6. Place sealing compound on the threads of the compression fittings and thread onto the tank boss. Tighten the compression fitting completely.
7. Place the standpipe into the tank hole at an angle. Slip one side of the tank boss inside the hole.
8. Bring the standpipe up vertically and insert the other side of the tank boss through the tank hole.
9. Center the standpipe in the fuel tank hole.
10. Pull up on the standpipe and tighten in place with the clamping nut. Do NOT over-tighten the nut to prevent the rubber washing becoming distorted.

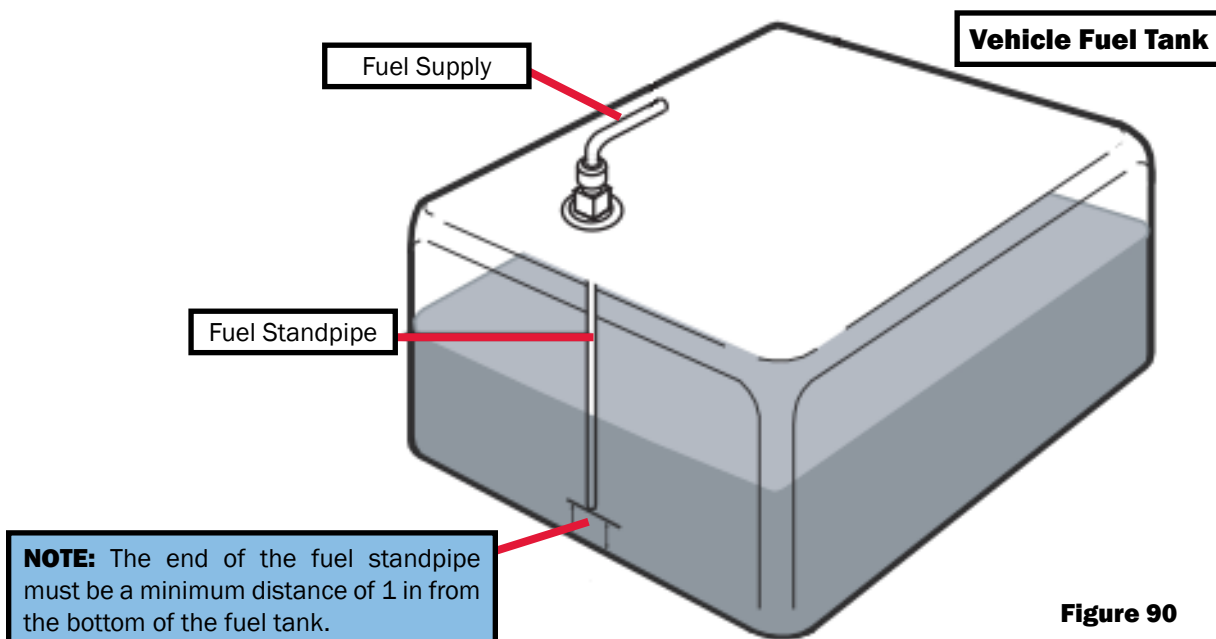

Figure 90

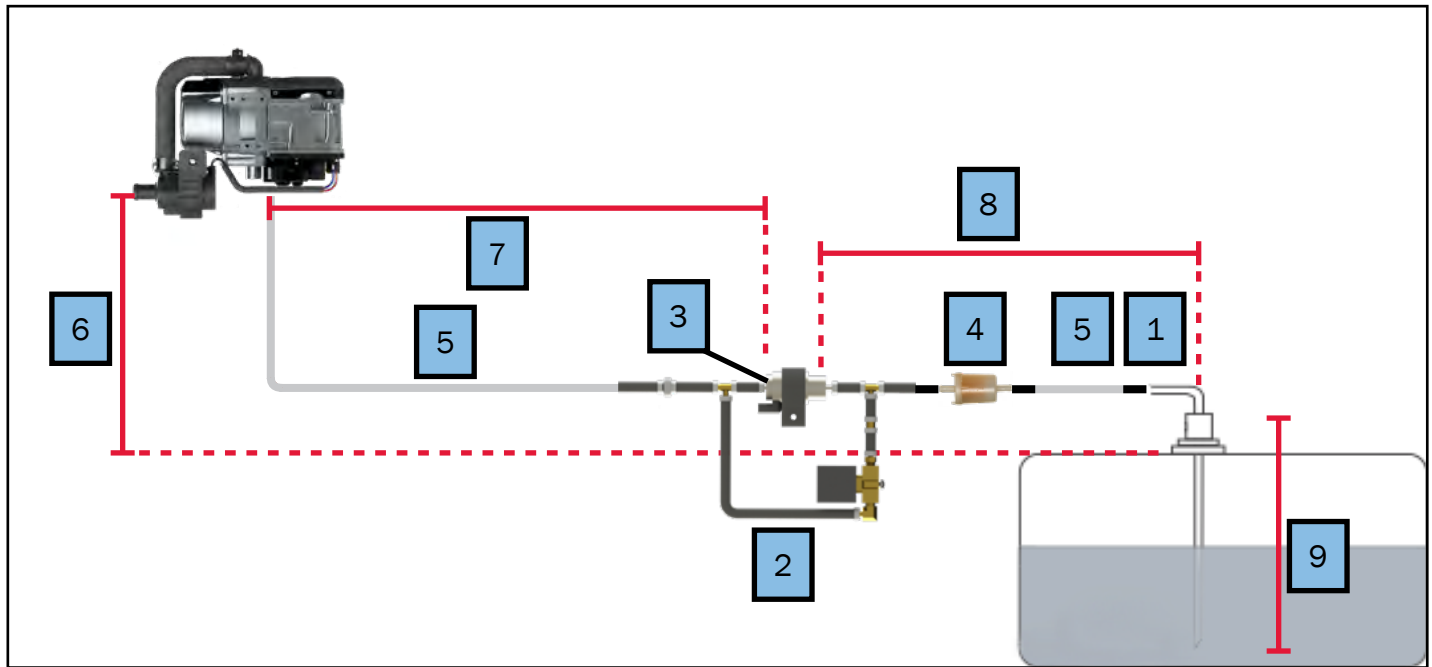



Figure 91

1. Fuel Line Coupler
2. High Altitude Bypass
3. Fuel Pump
4. Fuel Filter
5. Fuel Line
6. Max Delivery Height (6) = 9'9"
7. Max Delivery Length (6 + 7) = 28' 3"
8. Max Suction Length (8 + 9) = 9'9"
9. Max Suction Height (9) = 3' 3"



WARNING

Do NOT use bio-diesel with the copper fuel lines. Doing so will result in damage to the burner and fuel system. Please follow instructions to ensure safe operation. Always check for any fuel leaks before operating the burner.

Fuel Lines Requirements

- Please refer to the example diagram shown above.
- Use the provided 5mm x 1mm fuel line with the included couplers and clamps. Reference Figure 92.
- The fuel line should not be descending from the fuel pump to the burner - see Figure 91.
- The fuel line should be properly secured to avoid sagging.
- The fuel line must be installed in a manner that won't cause damage to the fuel line (i.e. close to exhaust).
- The fuel line must be secured to the connections by hose clamps.
- The fuel line should be mounted and secured with hose clamps. The hose clamp must be tightened so that the two tabs on the clamp touch each other.
- The fuel line must be only steel, copper, rubber, or plastic lines made of plasticized, light, and temperature-stabilized PA 11 or PA 12.
- If more fuel line is needed, an Aqua-Hot Fuel Line Kit is available for purchase (PLE-125-FL1).

Fuel Filter

- A fuel filter should be installed to ensure that clean fuel is delivered to the burner at all times. The fuel filter type should be 25-30 microns.
- Make sure the fuel filter is installed in an accessible area, so it can be replaced during service.
- The filter can be mounted vertically or horizontally; note the installation position and direction of flow (see Figure 96).

Fuel Pump

- The fuel pump is a combined pumping, metering, and shut-off system. It pumps fuel from the vehicle supply to the fuel connection piece to the burner via the fuel lines.
- The High Altitude Bypass is installed with the fuel pump for use in altitudes over 5,000 ft.
- Fuel Pump is required to be installed horizontally. It is not recommended to mount the assembly rotated 180° (see Figure 93).

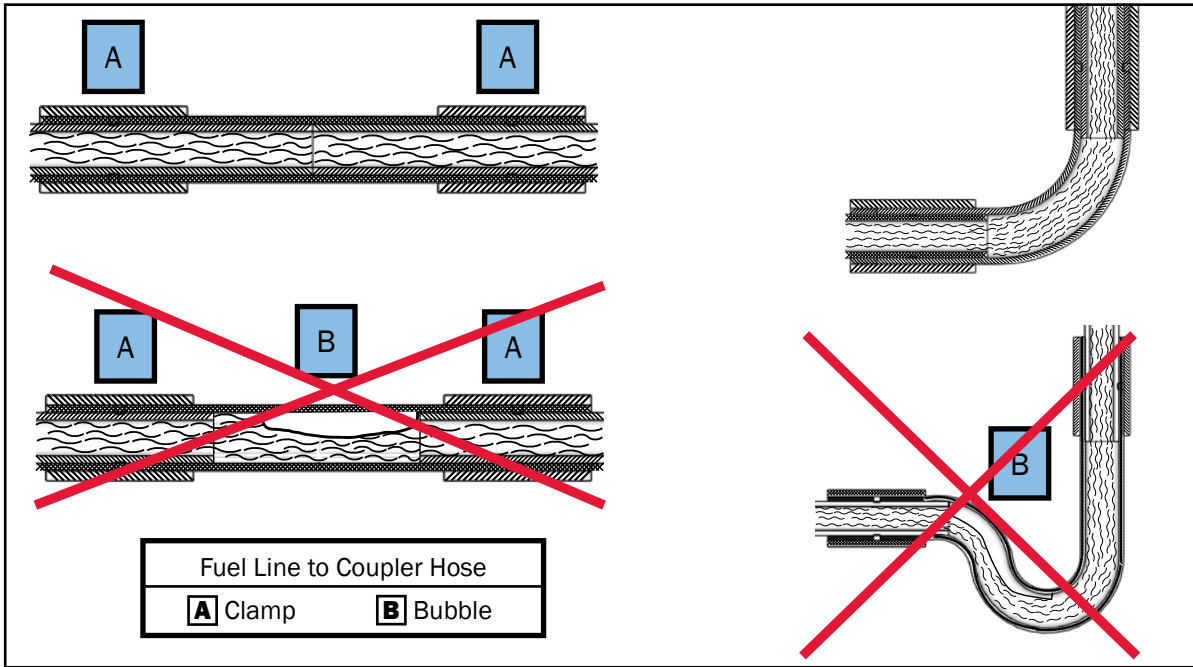

Figure 92

NOTE: The fuel lines must be secured and supported properly to avoid air traps or bubbles. Avoid unnecessary dips or bends, the line should not run downward from the fuel pump.

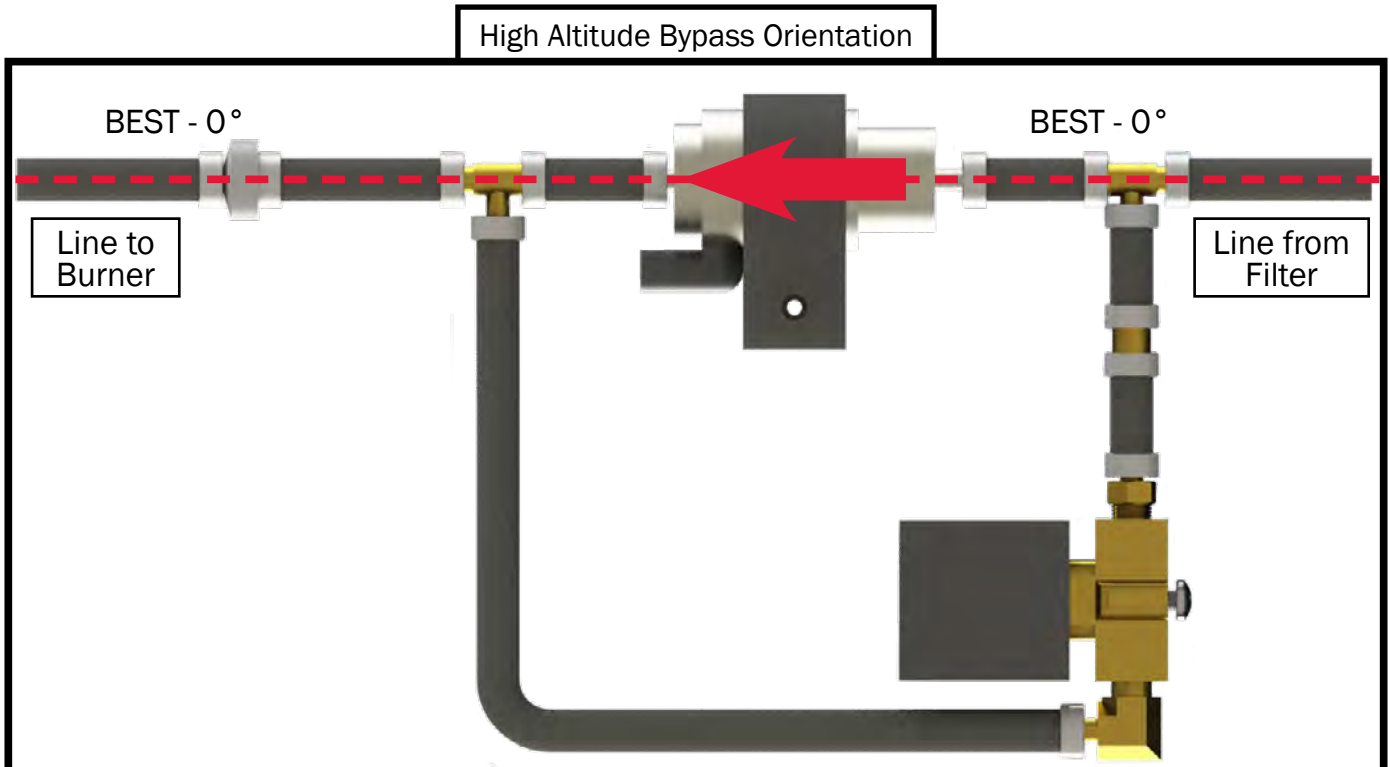

Figure 93

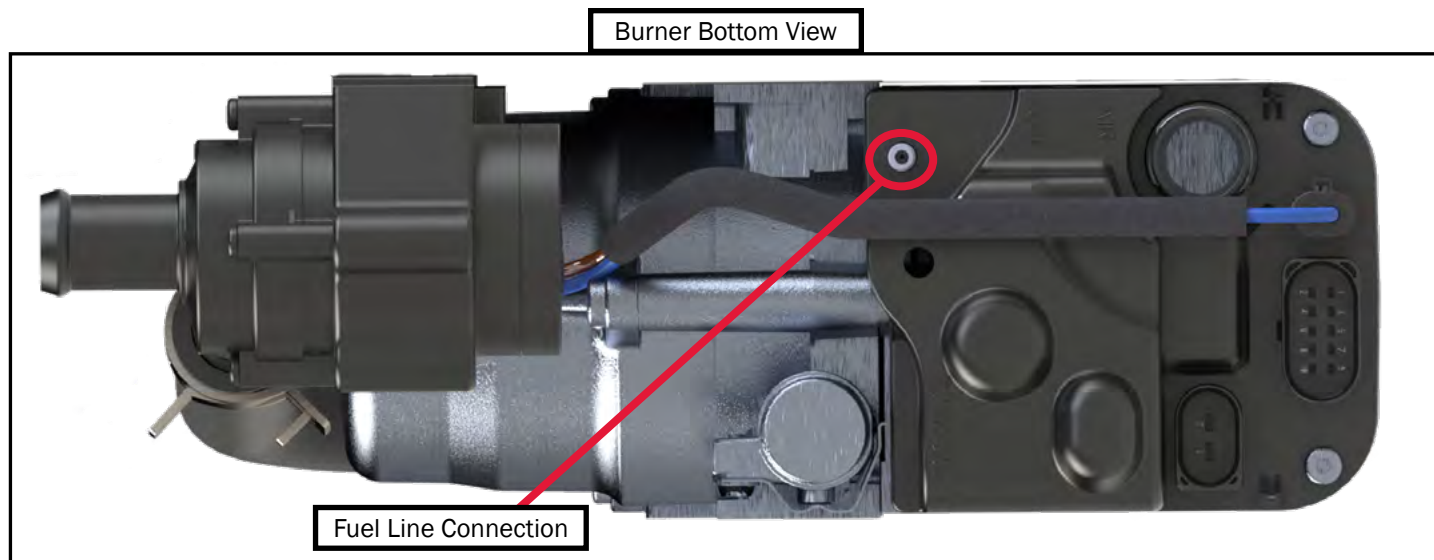

Figure 94

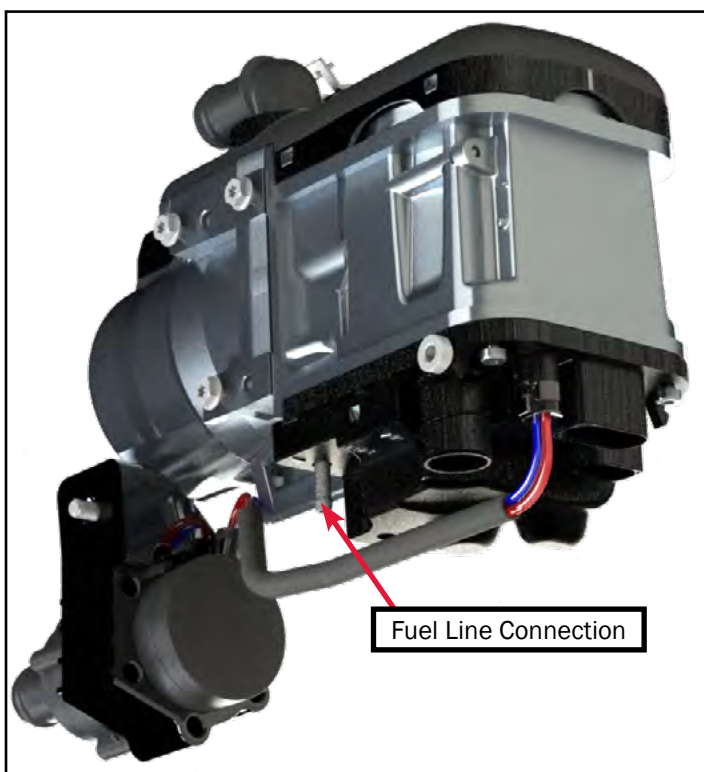

Figure 95

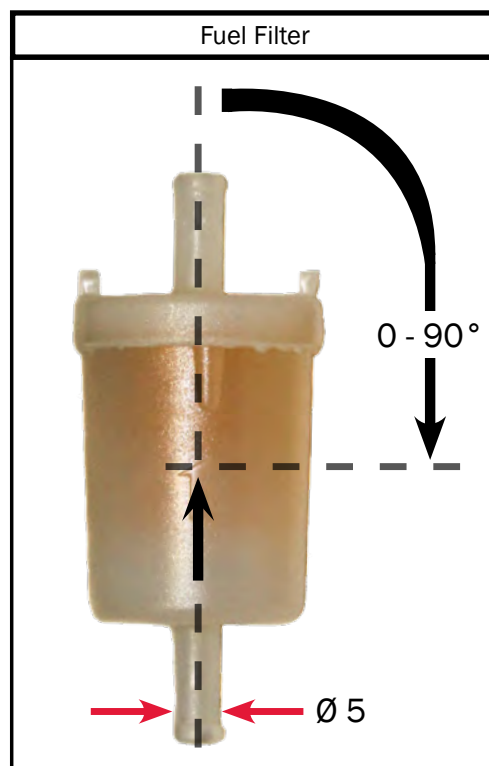

Figure 96

Fuel Purge Procedure:

The fuel lines should be automatically primed with the first operation of the burner. It may need to be power cycled a few times (3-4 times) to purge any air. Perform this procedure once the burner and Aqua-Hot are completely installed and the Aqua-Hot is adequately filled and purged.

NOTE: DO NOT run the diesel burner without the coolant filled and purged as it will cause serious damage to the burner.

1. Connect a 6V power source to the fuel pump to pulse the pump. The power source must be able to be pulsed (turned on and off) rapidly, for this process.



WARNING

Do NOT exceed 6V when powering the fuel pump. This can cause irreparable damage to the fuel pump.

- The pump can be powered with wire and gator clips.
- The pump pin numbers can be found on the inside of the housing where the pins are found.

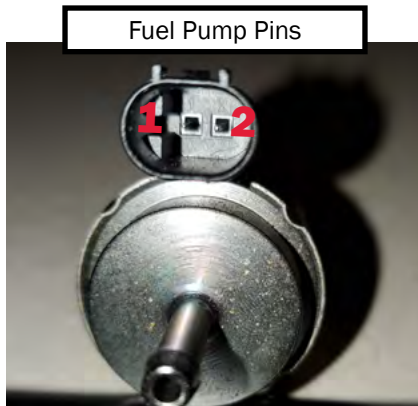

Figure 97

- Ground goes to Pin #1
- Power goes to Pin #2
- If you would rather use a plug instead of the wire and gator clips, the mating part numbers needed for the connector are:
 - Housing: 1-967644-1
 - Terminal; 0965906-1
 - Seal: 0-967067-1

2. Pulse the fuel pump at a steady 1-2 pulses per second until fuel begins to come out of the fuel line where it will connect to the burner.
3. Connect the fuel line to the burner.
4. Ensure all hose clamps and fuel fittings are tight and properly secured.
5. Ensure that the exhaust is well ventilated.
6. Turn the burner to ON at the screen (see Figure 98). The burner should cycle on because of the primed fuel lines.
 - There may be smoke from the exhaust on initial start-up, this is normal.
7. If the burner does not cycle on with the first start up, it will try a second time.
 - If the second start-up fails, there will be a fault message on the LCD screen (Figure 99). Tap the burner OFF at the screen.
 - Repeat Step 6.
 - If fault occurs again, repeat Steps 4-6.
8. After a successful start up, run the burner for 5 minutes.
9. After running the burner for 5 minutes, tap the HIGH ALTITUDE option on the LCD screen (see Figure 100) and run for additional 2 minutes.

After a complete, successful first operation, the fuel lines should be purged of any air and ready for normal operation and use.

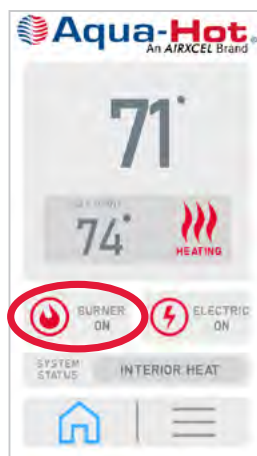

Figure 98



Figure 99



Figure 100

External Diesel Burner Troubleshooting

This section will cover any issues with the external diesel burner. The diesel burner is the primary heat source to the 125GN.

The troubleshooting procedures listed below are arranged in order of repair complexity. Do not replace parts without correctly determining the failure.

Follow the directions below in order to troubleshoot the diesel burner. Do not skip through the troubleshooting steps, as this may needlessly complicate unit diagnosis and repair.

Troubleshooting Procedure:

- Ensure that the system is supplied with electrical power and there are no blown fuses.
- Ensure that there is at least ¼ tank of fuel in the vehicle fuel supply and the fuel filter is not clogged.
- Make sure all the electrical and plumbing connections are connected and secure.
- Ensure there are no faults for the burner. If there are, determine the fault and remedy.

The fault is indicated by a flashing “fault” light on the LCD screen during heater operation. It is indicated on the diagnostic screen by the Burner Status ON/OFF indicator. There will be a series of rapid flashes, followed by 1 or more slow flashes. The rapid flashes are an alert indicator; the slow flashes should be counted, as that is the fault code. Refer to the table below for the fault code.

F00 (continuous flashing)	Burner interlock (lock-out)
---------------------------	-----------------------------

After 5 short signals, count the long flashes:

F01 (1 flash)	No start (after 2 attempts to start)
F02 (2 flashes)	Flame failure
F03 (3 flashes)	Under-voltage or over-voltage
F04 (4 flashes)	Premature flame recognition
F05 (5 flashes)	Not used
F06 (6 flashes)	Coolant temperature sensor interrupt or temperature sensor short-circuit
F07 (7 flashes)	Fuel pump interrupt or short-circuited
F08 (8 flashes)	Combustion air fan motor interrupt or blower motor short-circuit or incorrect speed
F09 (9 flashes)	Flame sensor interrupt or short-circuit
F10 (10 flashes)	Overheating
F11 (11 flashes)	Circulating pump interrupt or short-circuit
F12 (12 flashes)	Battery main switch short-circuit
F13 (13 flashes)	Output vehicle fan short-circuit
F14 (14 flashes)	Overheating sensor defective
F15 (15 flashes)	Pre-heating/ignition circuit defective
F16 (16 flashes)	Exhaust gas temperature too high
F17 (17 flashes)	Exhaust gas temperature sensor defective

After the fault cause has been eliminated, the burner must be switched on again.

Heater Lock-out Reset Procedure

The control unit continuously monitors the heater operation. The control unit identifies errors on individual burner components and faults during operation. Should the control unit experience component errors and operational faults, the burner may be shut down and not restart.

The burner lockout reset must be done manually as shown below.

Troubleshooting Procedure:

- Turn on the burner on the interior switch.
- Remove the main power connection to the burner or pull the fuse for a minimum of 20 seconds.
- Turn the burner off on the switch.
- Reconnect the main power connection that was previously disconnected.

External Diesel Burner

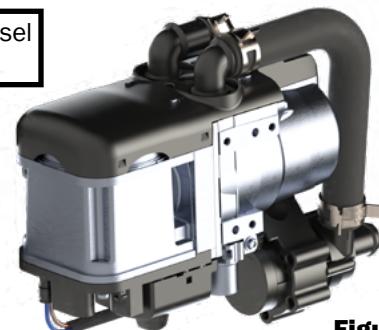

Figure 101

General Failure Symptoms of the Burner

This section will cover the typical failures of the diesel burner. Refer to the table more fails and their remedies.

Failure Symptom	Possible Cause	Remedy
Burner switches off automatically (fault lockout)	No combustion after start or automatic repeat start	Switch off burner and switch back on.
	Flame extinguishes during operation	<ul style="list-style-type: none"> Check coolant lines for obstructions, closed valves, and kinks. Check coolant level, purge any air. Allow burner to cool down. Check for failure codes.
	Burner overheats	<ul style="list-style-type: none"> Charge/replace batteries. Switch off burner and switch back on.
Heater is letting out black smoke from the exhaust	Combustion air and/or exhaust tube is blocked	Check combustion air intake and or/ exhaust tube.
Burner does not switch on	Heater is without electrical power	Check power supply to the unit and ground connections.
Burner switches off during operation (= fault lock-out)	Burner has overheated due to lack of coolant	Refill antifreeze and water mixture.

Service of the Burner

The service or maintenance should be done once a year to maintain the functional reliability of the burner. The service and any repairs must only be performed by trained technicians.

Proper preventive maintenance greatly improves the burner performance.

- Visual inspection of the burner for any external damage, fastening, and also external cleaning (make sure power is disconnected before any cleaning).
- Inspect electrical connections for corrosion, making sure they are all properly secured and free of any kinks, cracks, or damage.
- Check the exhaust and combustion air lines for signs of damage and make sure they are clear of debris or any blockages.
- Check fuel lines for any leaks, kinks, cracks, or damage.
- Check plumbing lines and circulation pump to make sure they are properly secured and free of any damage.
- Check the fuel pump and circulation pump for any damage.
- Run the burner for 20 minutes once a month.
- Clean the burner of any debris or dust with compressed air.
- Change the fuel filter once a year.

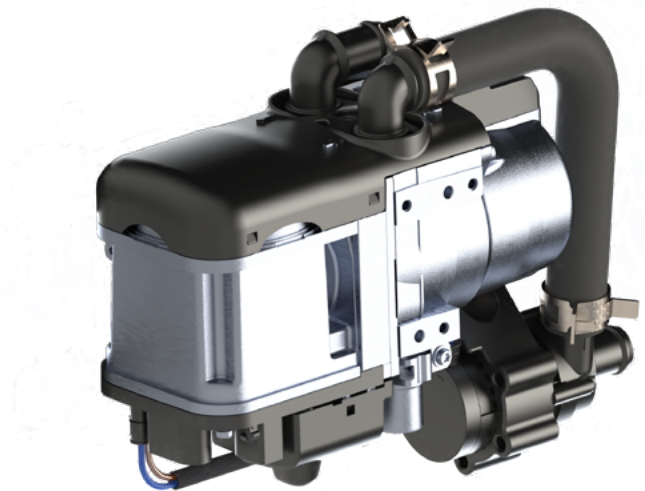

Figure 102

System Checks



WARNING

Never operate the burner in closed rooms such as garages or workshops that do not have proper ventilation. Please be sure to confirm all the system checks prior to the first operation.

Please do the following checks prior to the first operation to confirm the installation was done properly and safely.

1. Confirm that the Aqua-Hot 125DN is fully and properly installed. It must be adequately filled of fluid and purged of any excess air.
2. Confirm the burner is properly and securely mounted, all bracket fasteners are tightened.
3. Confirm that there is ample space between the burner and any heat-generating parts such as the exhaust.
4. Confirm that there is ample space between the burner and any moving vehicle parts during all system operations.
5. Make sure the burner is installed in location that is free from any splashing water or debris, and protected from other components installed in the same compartment.
6. There should be substantial separation from the burner and the ground.
7. There should be enough space between the vehicle body and any heat-generating components like the exhaust and burner.
8. Ensure there is protection on any sharp edges or objects.
9. Confirm that all of the plumbing and fuel lines are free from any kinks or sharp bends, and are not pinched or could be potentially cut.
10. Make sure all the hose clamps are properly positioned and secured.
11. Ensure that there is an adequate amount of fluid in the system, and it has been purged of any air.
12. Make sure there is more than a ¼ tank of fuel and the operating voltage to greater than 11.5V.
13. Confirm that the plumbing lines leading from the burner to the 125DN are below the expansion bottle.
14. Ensure that all wiring is properly secured and away from any moving parts or heat sources.
15. Make sure the power and ground connections are properly secured and installed.
16. Check all plumbing connections for leaks.
17. Check that the fuses are in their proper, specified locations.
18. Make sure the fuse boxes are secure and protected from any water sources.
19. Ensure the vehicle battery is mounted properly and all connections are secure, and has a full charge.
20. Make sure the fuel standpipe is properly and securely mounted in the fuel tank.
21. The standpipe should not interfere with the vehicle fuel delivery system. Check the fuel gauge for proper operation.
22. Confirm all fuel lines are secured and spaced safely away from exhaust or other heat-generating components.
23. Make sure the fuel pump is installed in a cool place. It is recommended to install the fuel pump in the same location as the vehicle fuel tank.
24. Make sure the exhaust and clamps are properly secured.
25. The exhaust tube should be a safe distance from any flammable materials (at least 2in).
26. Confirm there are holes drilled in any low points in the exhaust tube.
27. Exhaust opening should be a safe distance away from any vehicle interior openings and should be directed to not cause back pressure while driving.
28. The combustion air intake should get fresh air away from the direction of travel.
29. Ensure the air intake system is properly secured.
30. All plumbing and fuel lines should be purged of any air, as any air can cause a lock-out.

Once the system checks are complete and it has been confirmed that all is properly and safely installed, please continue to the first operation.

NOTE: The burner must not be started until it has been properly checked by a professional technician. The burner must be installed professionally in accordance to the installation instructions.

Please do the following checks prior to the first operation to confirm the installation was done properly and safely.

- Make sure the fluid temperature is below 122°F.
- Check all connections for leaks.
- CO₂ settings should be set to factory settings.
- Refer to the troubleshooting procedure if the heater switches to fault lock-out condition.

Aqua-Hot First Operation

Activation Instructions (Electric Element):

1. Make sure power supply to the Aqua-Hot is on.
2. Confirm that the antifreeze and distilled water heating solution is adequately filled.
3. Confirm the system and heating loop has been properly purged of any air.
4. Make sure to flush the domestic water system thoroughly with clean water prior to use.
5. Tap the electric element to "ON" on the Aqua-Hot 5in LCD screen to supply the 120V AC electric element with power.

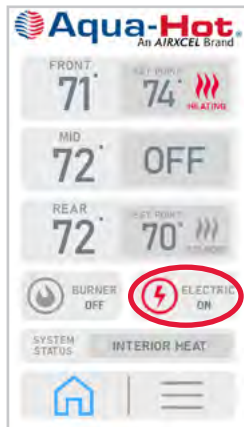

Figure 103

6. Allow approximately 20 minutes for the electric element to heat the tank. Turn on a hot water faucet, and allow to run until hot water flows. Once there is hot water, close the faucet. This will verify that the electric element is operating as it should.

Once these checks have been confirmed, the electric heating element is now ready for normal operation and use.

Continue to the next procedure to activate the external diesel burner.

<p>LDE-200-810</p>	<h1 style="margin: 0;">WARNING</h1>
	<p>Burn Hazard</p> <p>Hot Coolant Circuit with Hot Surfaces can cause severe burns.</p> <p>DO NOT touch or service until equipment has cooled.</p>

The first operation of the burner with the Aqua-Hot may not light up perfectly. This is normal and may take a couple tries to get the fuel lines purged of air before a successful start-up.

NOTE: Make sure to perform the fuel line purge procedure on Page 44 prior to starting this initial start up of the burner.

Activation Instructions (Diesel Burner)

1. Make sure there are no blockages or debris to the exhaust outlet or combustion air inlet.
2. Make sure the plumbing lines and fuel lines are properly purged and free of air.
3. Make sure there is adequate fuel in the vehicle fuel tank (at the least ¼ tank).
4. Turn on the burner on the heater control switch.

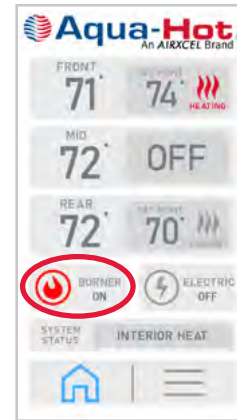

Figure 104

5. Once the burner turns on, the circulation pump and combustion air fan should run (can be determined by listening).
6. The burner should start up after approximately 120 seconds. This can be determined by the hot exhaust exiting from the exhaust tube.
7. Allow the burner to run a full cycle. Turn on the heat or hot water inside the RV to confirm the burner is properly operating.

NOTE: It is recommended to run the burner for at least 20 minutes every month to ensure optimum heater condition.

Once these checks have been confirmed, the diesel burner is now ready for normal operation and use.

NOTE: Both the electric heating element and the external diesel burner are thermostatically controlled. The element and/or burner will automatically maintain the temperature of the boiler tank's antifreeze and water heating solution.

Winterizing the Aqua-Hot

The Aqua-Hot's domestic water heating system must be completely drained of domestic water at any time the heater is stored where freezing temperatures may be experienced.

Please follow these instructions when winterizing the Aqua-Hot domestic water heating system. Reference Figure 105 for a system overview.

NOTE: The Aqua-Hot can continue to be used for interior heat once the domestic hot water system has been winterized.

1. Completely drain the fresh water storage tank.
2. Disconnect the domestic water demand pump suction line from the fresh water storage tank.
3. Attach an adequate piece of hose onto the suction side of the domestic water demand pump.
4. Place the opposite end of the hose into an adequate supply of non-toxic RV winterization antifreeze (FDA certified as "GRAS" Generally Recognized As Safe must be used) and allow the fluid to pump through.
5. Open and close all interior and exterior water faucets one at a time, until ONLY pure RV antifreeze is present. Perform this procedure for both cold and hot water faucets.
6. Remove the hose and reconnect the domestic water demand pump's suction line to the fresh water storage tank.

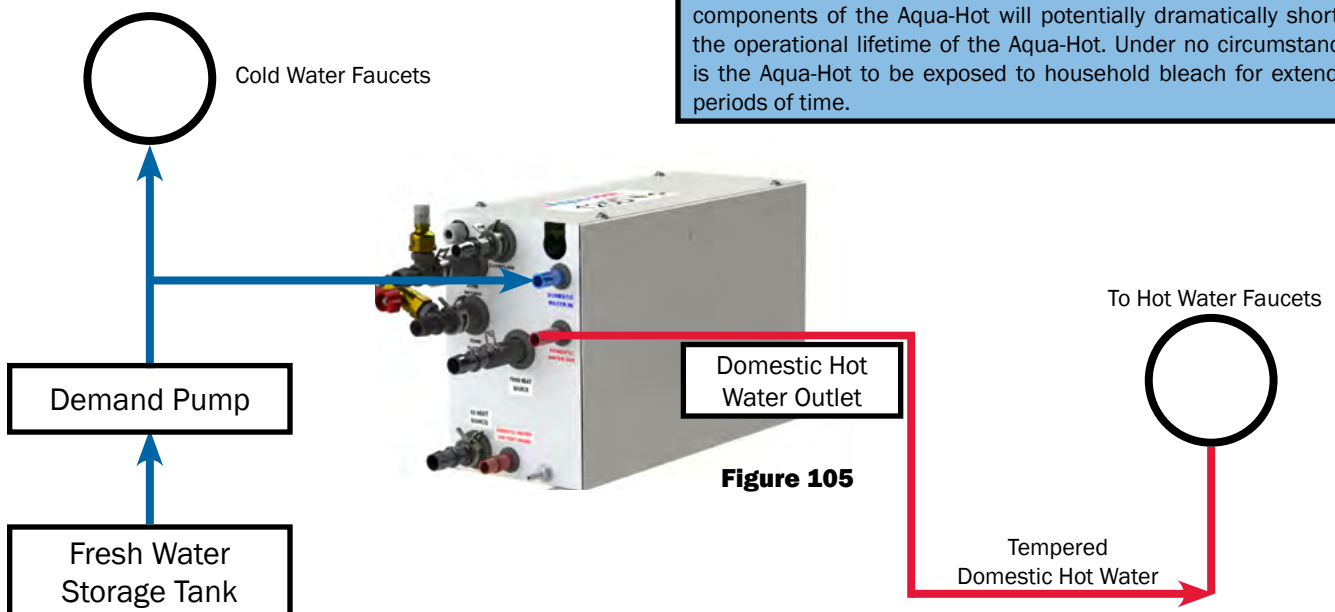

WARNING

Not winterizing the Aqua-Hot when freezing temperatures are present will result in serious damage to the Aqua-Hot domestic water heating system. Ensure that only non-toxic RV antifreeze (FDA approved "GRAS" antifreeze) rated for winterization is used when winterizing this unit. The warranty does not cover freeze damage.

Disinfecting the Domestic Water System

NOTICE

The Aqua-Hot Heating components are not compatible to prolonged exposure to sodium hypochlorite (bleach or liquid bleach). Using products containing bleach, including water refreshers, may cause corrosion of the domestic water lines, resulting in a catastrophic failure of the Aqua-Hot system by creating leaks that cannot be repaired. This damage is not covered by the Aqua-Hot warranty.

If disinfecting the hot water system, be sure to follow NFPA 1192 Standard of Recreational Vehicles "Instructions for Disinfection of Potable Water Systems" or any other applicable local standards for Potable Water Systems.

NOTE: Extended exposure to household bleach will corrode the components of the Aqua-Hot will potentially dramatically shorten the operational lifetime of the Aqua-Hot. Under no circumstances is the Aqua-Hot to be exposed to household bleach for extended periods of time.

AH100 Series

With Standard 1.5kW / 120VAC Tank Heater and Diesel Burner



3-Way Valve Controls Coolant Flow Path For Interior or Hot Water Heating
 Interior Heat: Orange Path.
 Hot Water: Green Path

During Interior Heat Operation when Domestic Water Flow is detected, the 3-Way Valve will switch automatically providing all heating power for heating the water.

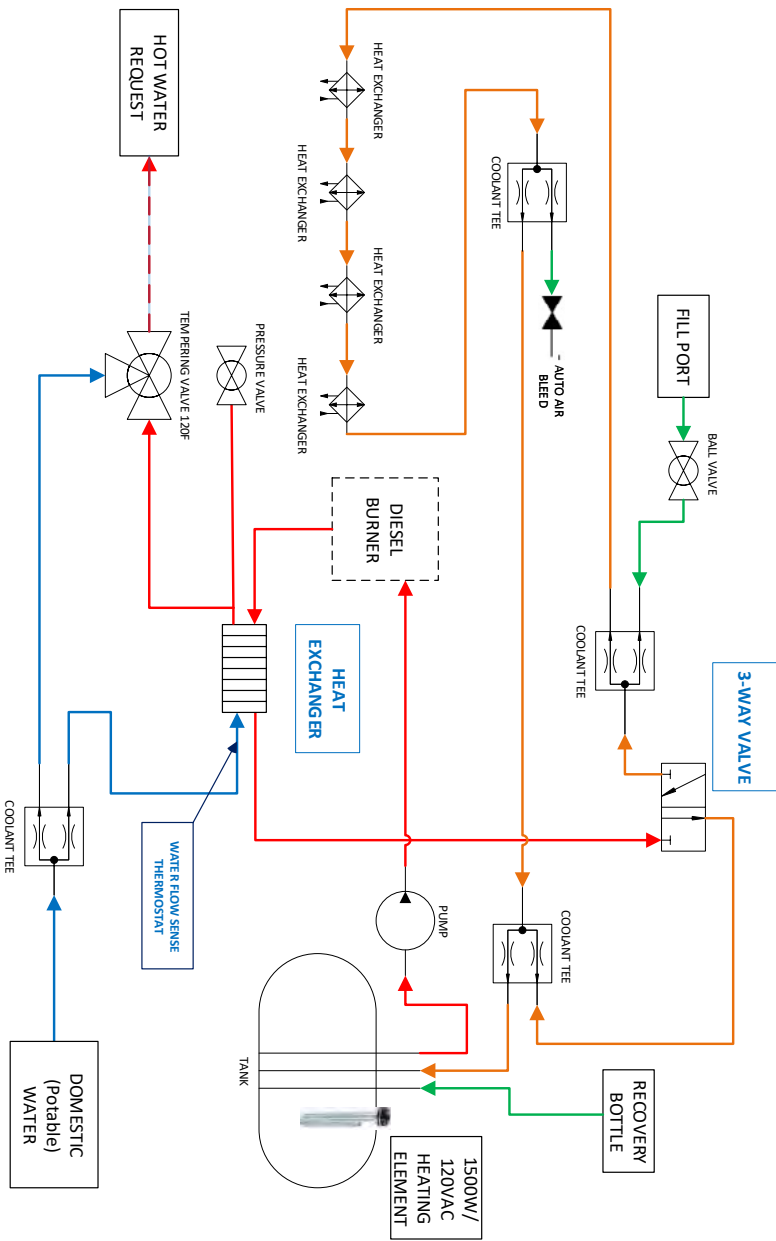

PIN OUT INFORMATION

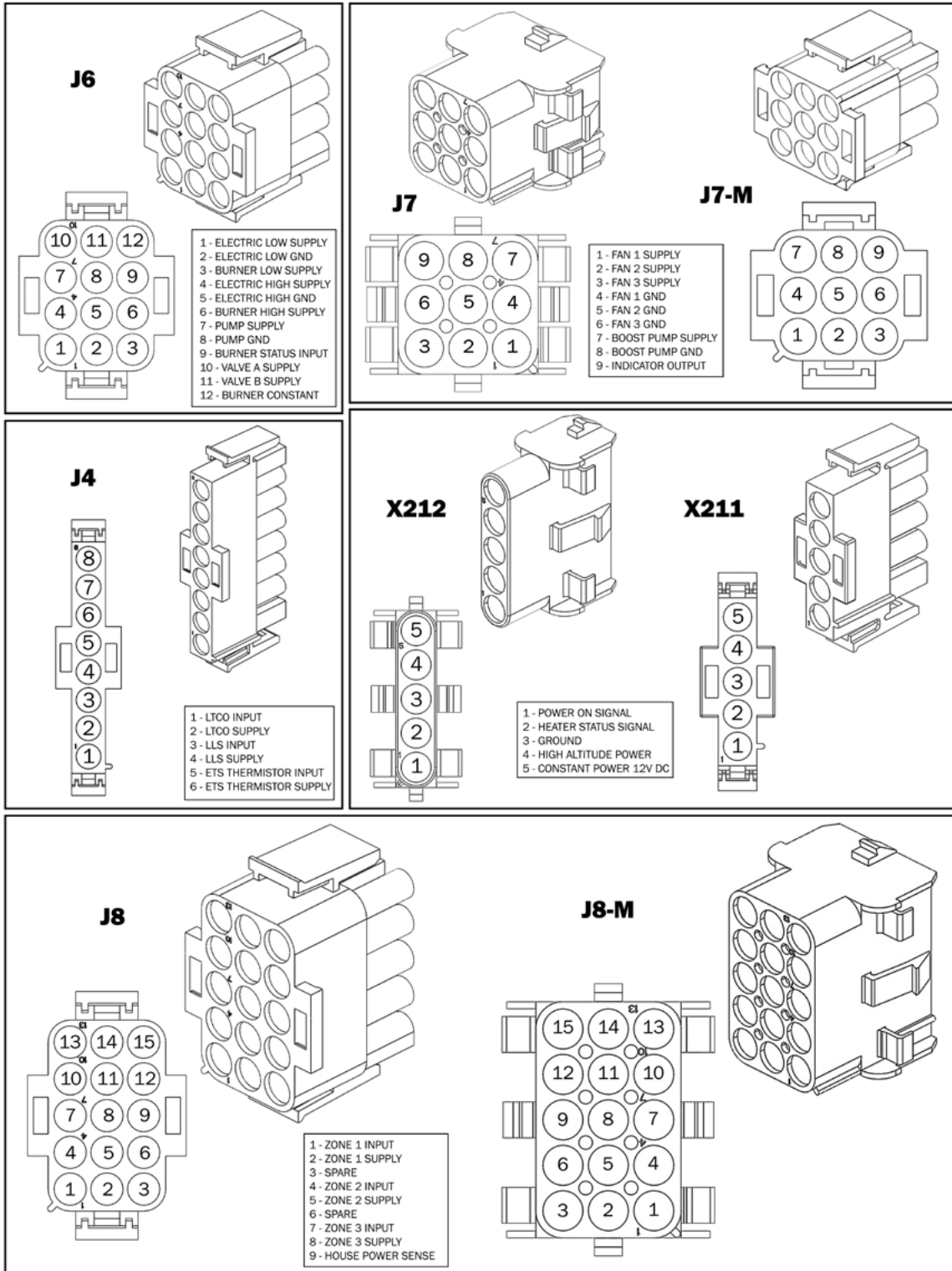

NOTE: All connectors are shown from Pin insertion side.

CONNECTOR	MATE PART #	FLAMMABILITY RATING
J4	640582-1	UL94V-0
J6	1-480708-0	UL94V-2
J7	1-480706-0	UL94V-2
J8	1-480710-0	UL94V-2

CONNECTOR	SOCKET PART #	WIRE SIZE RANGE (AWG)
J4	350550-1	20-14
J6	350550-1	20-14
J7	350550-1	20-14
J8	350550-1	20-14

ZONE THERMOSTATS

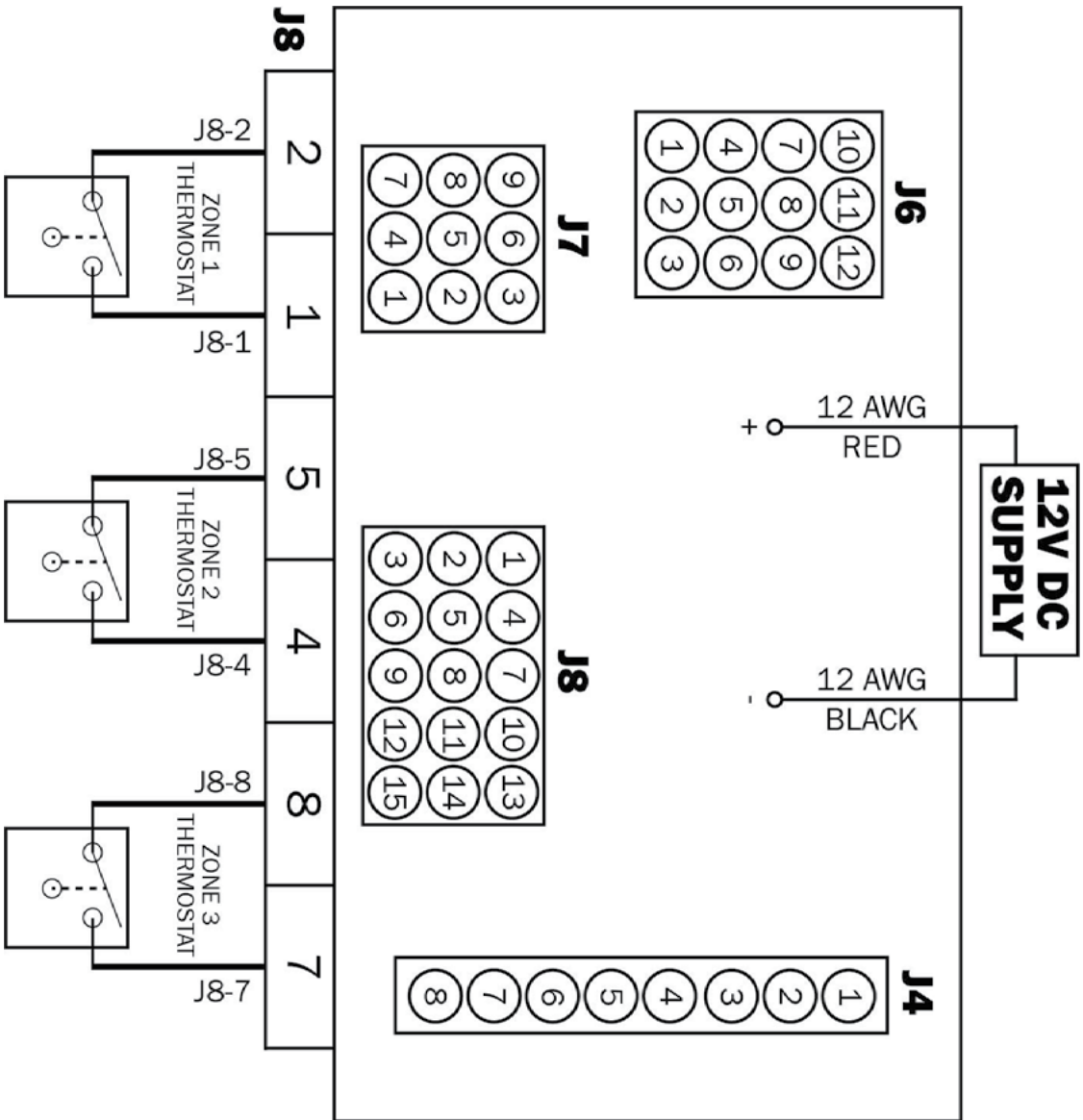

ZONE HEAT EXCHANGERS

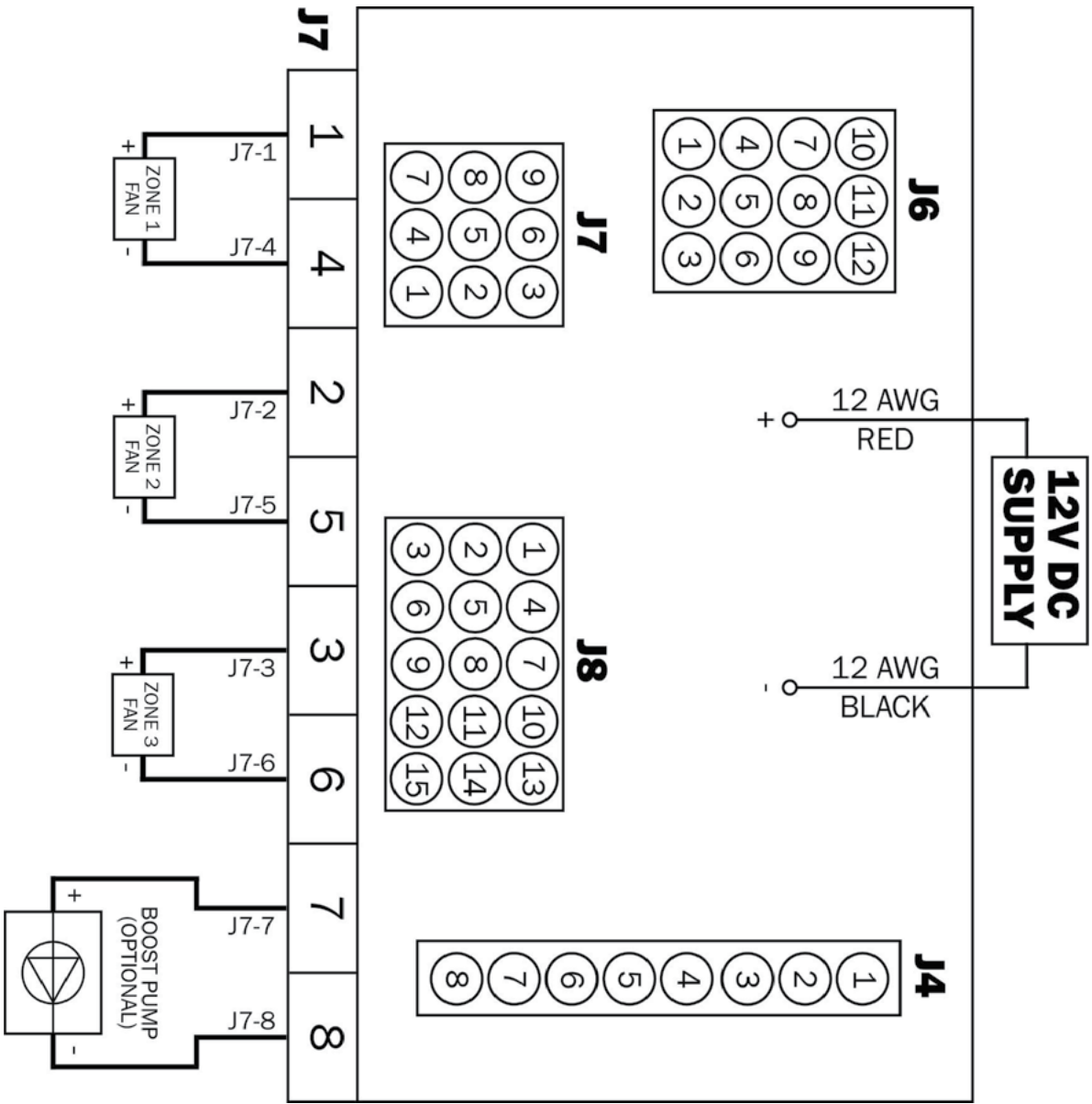

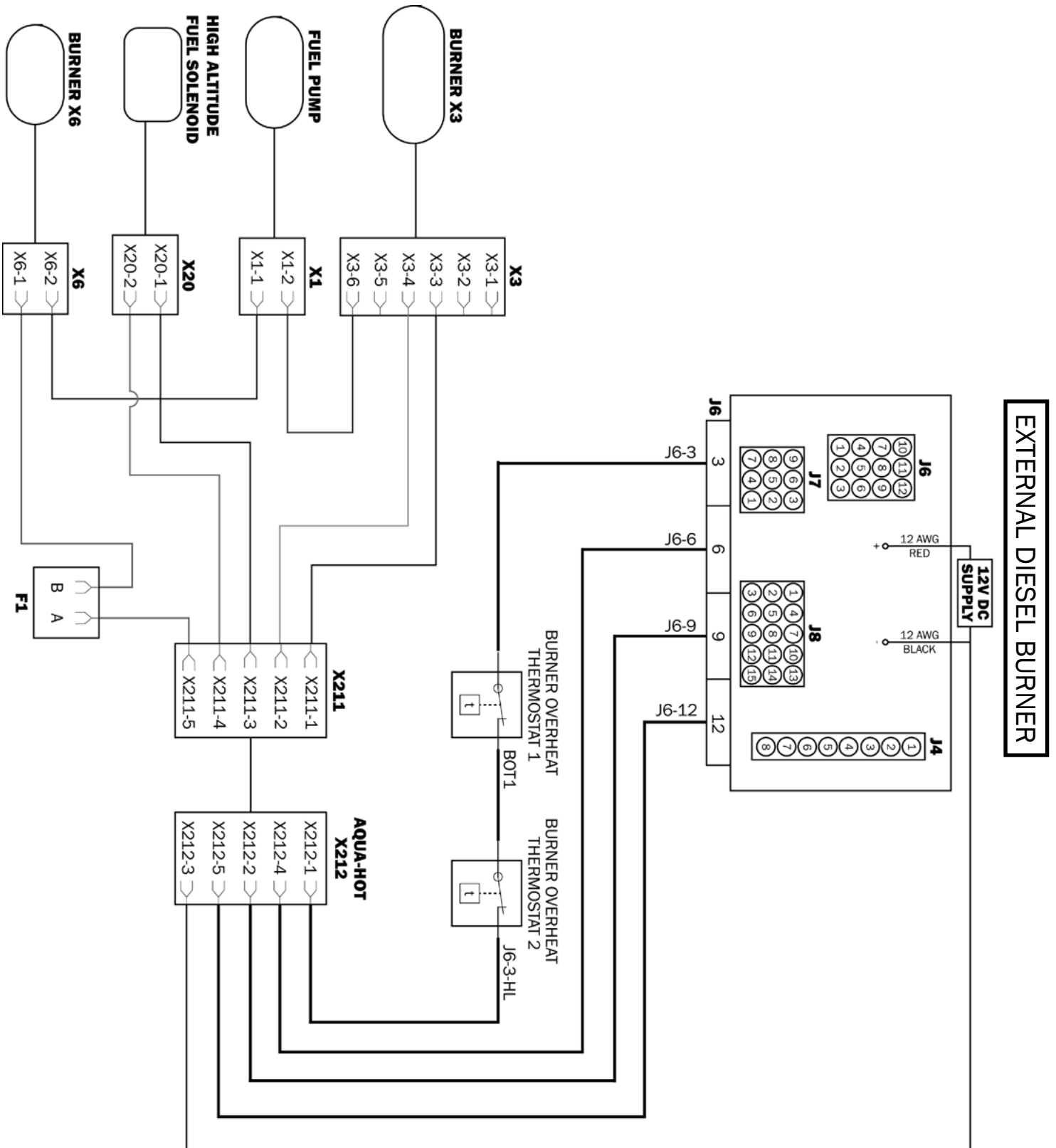

ELECTRIC ELEMENT

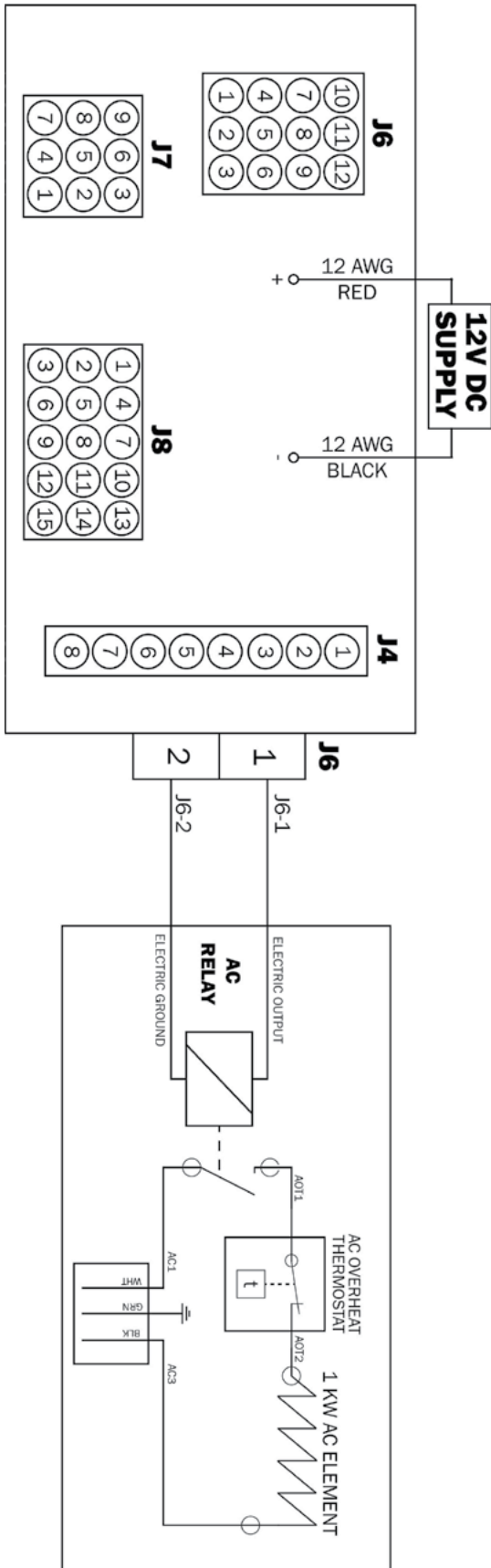

SENSORS AND THERMOSTATS

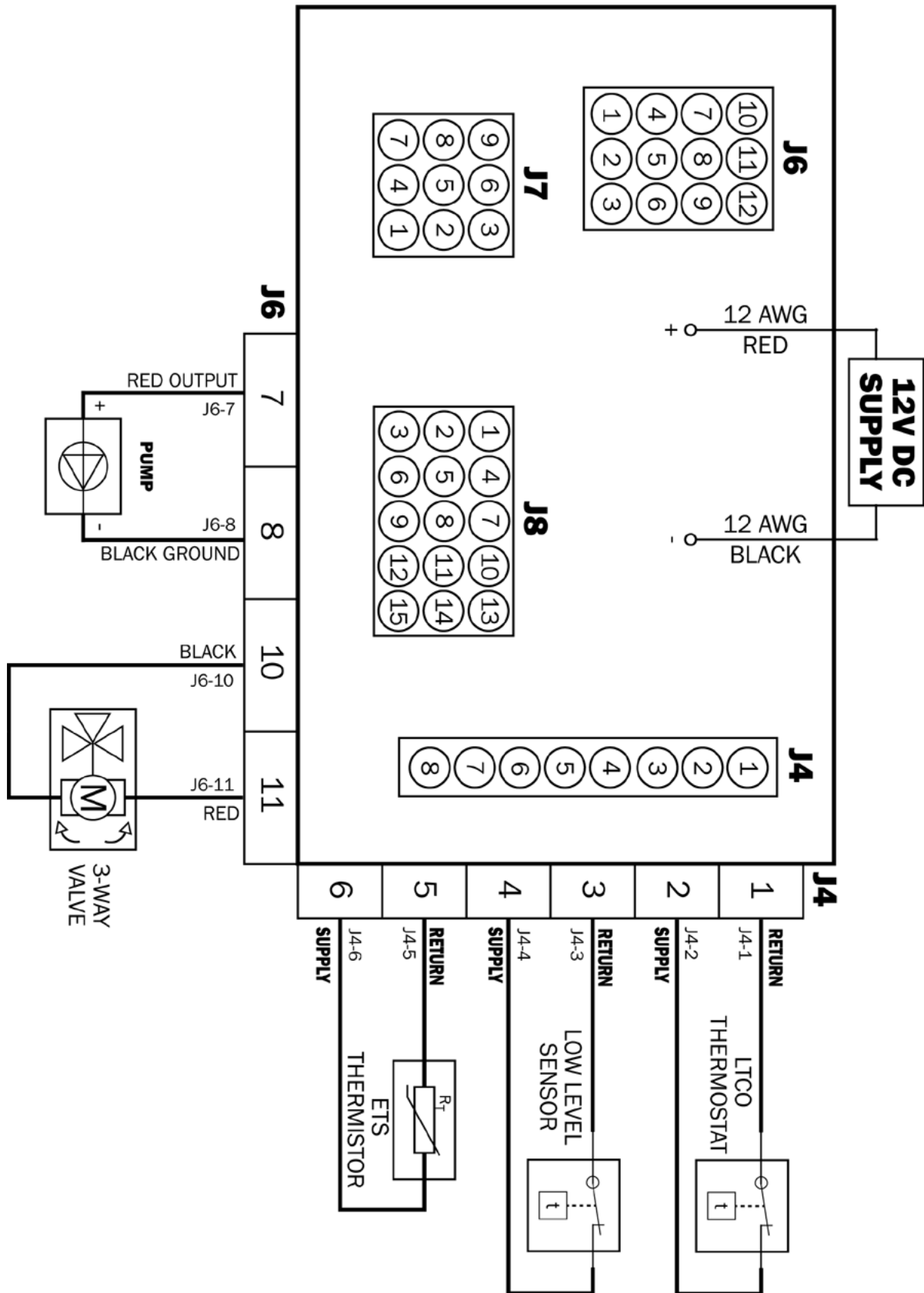

Measuring Antifreeze Using a Refractometer

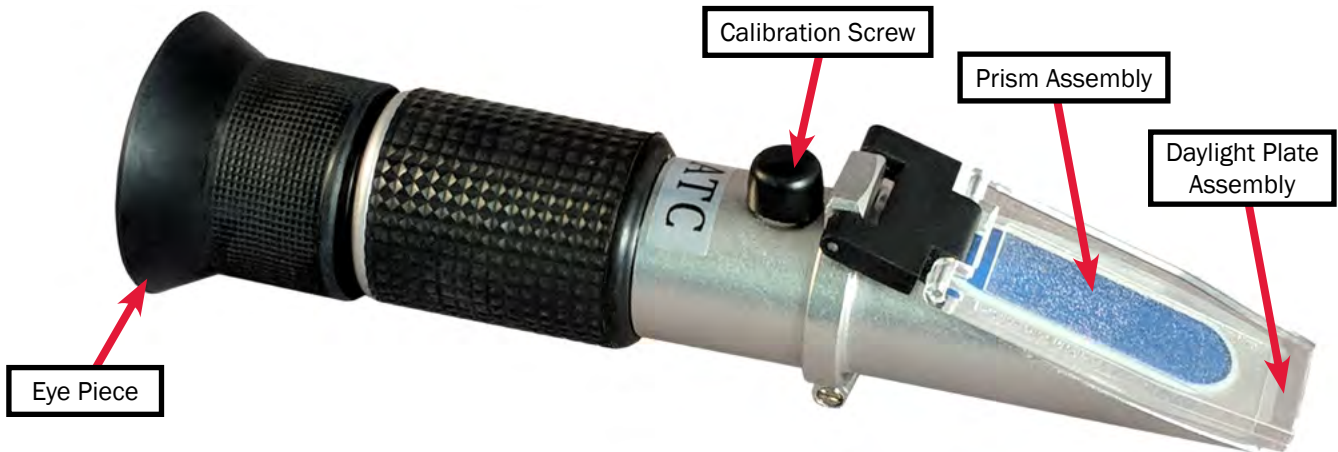

Properly Apply Antifreeze to the Prism Assembly

Use the guide below to properly apply the ethylene glycol mixture to the prism assembly of the refractometer. Once that is complete, peer through the eyeglass of the refractometer to continue to the next step.

Adjust the Boundary Line

Once the glycol solution has been properly applied, adjust the calibration screw until the boundary line labeled “Ethylene Glycol” is set to 32 °F. The graphic to the right has been designed as an aid, but note that it may differ from what is shown in the refractometer sight glass.

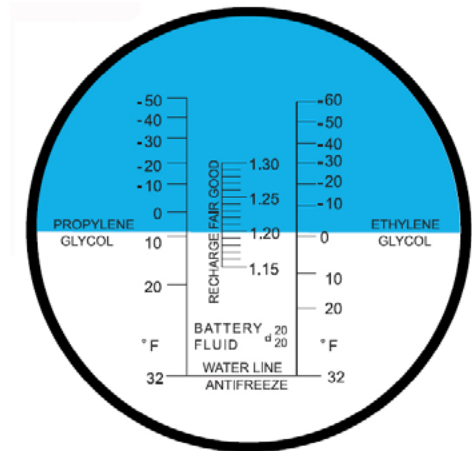

Application of Ethylene Glycol

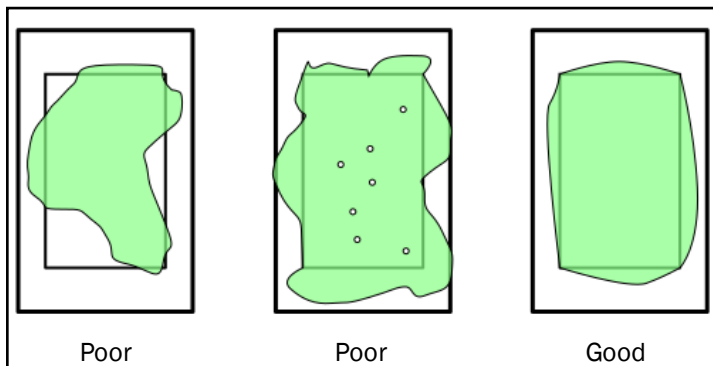

Refractometer Sight Glass

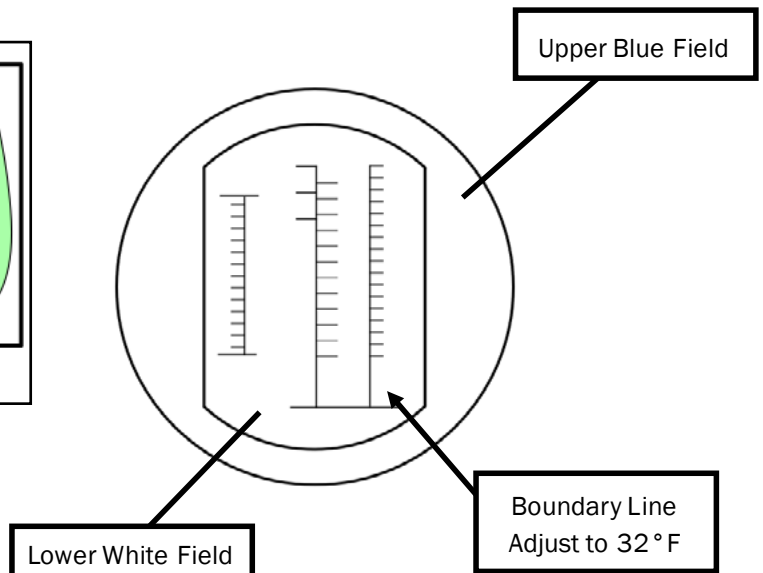

NOTE: Service parts and accessories are available through Aqua-Hot Factory Authorized Service Centers or www.aquahot.com. Click on the part number to route you to the Aqua-Hot web store for purchase.



[AHE-125-DN1](#)



[ELE-400-900](#)
Boost Pump Harness



[ELX-THM-309](#)
Thermistor, 10K, NTC, Room Temperature Sensor



[ELE-100-111](#)
Kit, RV-Side Controller Components



[EXE-103-OEX](#)
Heat Exchanger, Cozy III



[EXE-505-65A](#)

Heat Exchanger, Whisper Silent, 12V DC.



[EXX-006-500](#)

Grille, Long, 3.5" x 21.5", Black

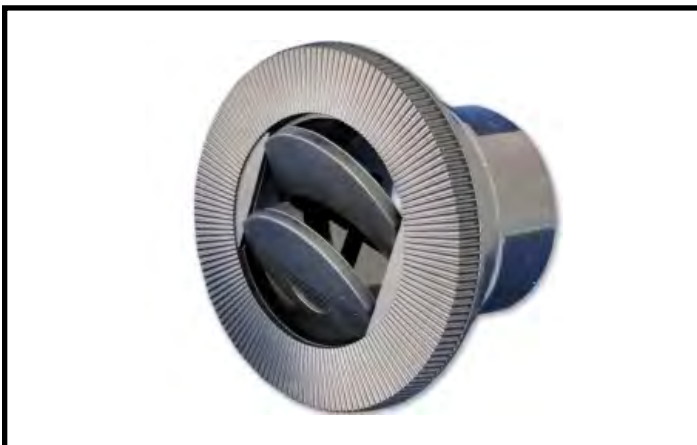

[EXX-013-100](#)

Nozzle, Round 4" w/o Connector, Black



[EXX-013-105](#)

Nozzle, 4" Round w/ 2-1/2" Connector, Black

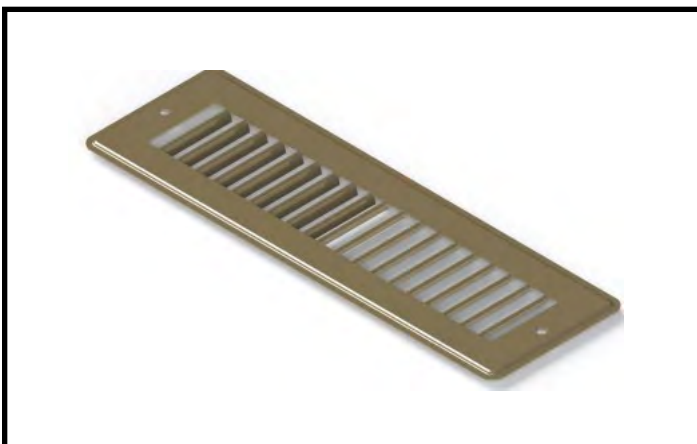

[EXX-950-411](#)

Grille, 10" x 2" Cozy



[EXX-006-501](#)

Grille, Medium, 3.5" x 15", Black



[PLE-125-FL1](#)
Kit, Fuel Line, 125DN



[PLX-000-200](#)
Tube, 5/8" Safety Stripe, 12ft.



[PLX-000-820](#)
Fitting, Elbow, 90°, 3/4", Barb, Black Nylon



[PLX-000-835](#)
Fitting, Reducer 3/4" to 5/8" Black Nylon



[PLX-100-900](#)
Boost Pump



[PLX-120-626](#)
Tube, 5/8", Red O2 Barrier Pex 100 Ft.



[PLX-200-103](#)

Fitting 1/2" (M) NPT x 3/4" Barb Black Nylon



[PLX-284-74V](#)

Hose, Molded, Elbow 90°



[PLX-432-000](#)

Fitting, Straight, 1/2" PEX x 1/2" (M)NPT PSF



[PLX-803-000](#)

Fitting, Straight, 1/2" PEX x 1/2" (F) NPT



[PLX-803-ELB](#)

Elbow Fitting, 90°, 1/2" PEX x 1/2" PSF



[PLX-803-FSE](#)

Elbow Fitting, 90°, 1/2" PEX Fitting



[PLX-CTB-270](#)

Clamp, Hose, Constant Tension, 3/4"



[PLX-A51-106](#)

Bend Support, 5/8"



[PLX-A65-200](#)

Fitting, Brass Barb, 3/4" x 1/2" (M) NPT



[PLX-A65-300](#)

Fitting, Brass Barb, 90°, 3/4" x 1/2" (M) NPT



[PLX-T44-006](#)

Fitting, Insert Modified Bras



[SME-102-000](#)

Cozy Plenum Assembly



2-YEAR LIMITED WARRANTY AQUA-HOT® HYDRONIC HEATING SYSTEM

Aqua-Hot Heating Systems Inc. warrants the Aqua-Hot Heater to be free from defects in material and workmanship under normal use and service for a period of two years on both parts and labor commencing upon the original date of registration of the vehicle. Replacement parts are warranted for the remainder of the Heater's standard warranty coverage or for six months, whichever is greater. The intent of this warranty is to protect the heater's end-user from such defects, which would occur in the manufacturing of the product. Thus, problems due to improper specifications, improper installations, improper use, the use of accessory parts or parts not authorized by Aqua-Hot Heating Systems Inc., repair by unauthorized persons, and damage or abuse of the heater are specially excluded from warranty coverage.

For additional information, or to obtain a warranty repair authorization, please contact the Aqua-Hot Heating Systems Warranty Administrator at 574-AIR-XCEL (574-247-9235) (7:00 AM to 4:00 PM Mountain Standard Time) or visit www.aquahot.com.

My Comfort Zones are On-Board

Vehicle:

Purchased From:

Dealer Information:

Name:

Location:

Phone Number:

Heating System:

Serial Number:

Installation Manual

100_{SERIES}

 **Aqua-Hot**[®]
An AIRXCEL Brand



Aqua-Hot Heating Systems, LLC
7501 Miller Drive, Frederick, CO 80504

Visit us online at www.aquahot.com
Call us at (800) 685-4298 or (303) 651-5500

©2022 Aqua-Hot Heating Systems, LLC. Printed in the USA